



Not to be distributed outside of FM Approvals and its affiliates except by Customer

APPROVAL REPORT

**KIDDE FIRE PROTECTION GX-20
25 BAR ENGINEERED, UNBALANCED
FIRE EXTINGUISHING SYSTEM
USING FM-200® CLEAN AGENT**

Prepared for:

**Kidde-Fenwal, Incorporated
400 Main Street
Ashland MA 01721**

Project: 3022566

Class: 5612

Date of Approval: FEBRUARY 3, 2005

Authorized by:

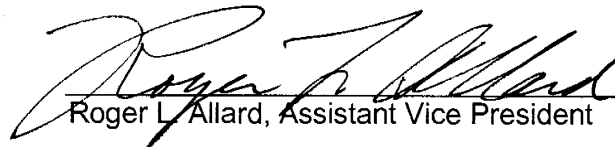
Roger L. Allard, Assistant Vice President

FM Approvals
1151 Boston-Providence Turnpike
PO Box 9102
Norwood, MA 02062

**KIDDE FIRE PROTECTION GX-20
25 BAR ENGINEERED, UNBALANCED
FIRE EXTINGUISHING SYSTEM
USING FM-200® CLEAN AGENT**

from

**Kidde-Fenwal, Incorporated
400 Main Street
Ashland, Massachusetts 01721**

I INTRODUCTION

- 1.1 Kidde-Fenwal, Incorporated requested an Approval examination of Kidde Fire Protection, Thame, Oxfordshire, United Kingdom as an Approved Product Modifier for their ECS unbalanced fire extinguishing system using FM-200® clean agent, to be designated GX-20 for Kidde Fire Protection.
- 1.2 This ECS system is currently Approved. The Approval report history is tabulated below.

Relevant Kidde-Fenwal ECS System Reports

Project	Report Title	Report Date
1Y5A2.AF	Fenwal Model 9300 and Kidde ECS Series Engineered Fire Extinguishing Systems Using FM-200 Extinguishing Agent	31 October 1996
3014861	Kidde ECS Series Flow Calculation Version 3.03 Fenwal Model 9300 Flow Calculation Version 3.03 Revised Class "A" Fire Extinguishment Concentration	20 September 2004

- 1.3 Kidde Fire Protection, a sister organization to Kidde-Fenwal, will produce a slightly modified version of the system, locally source some components, and fill the storage cylinders in their facility. Kidde-Fenwal has provided all necessary engineering and manufacturing information to Kidde Fire Protection to successfully accomplish these modifications.
- 1.4 This Report may be freely reproduced only in its entirety and without modification.
- 1.5 **Standards**

Title	FM Approvals Number	Class	Date
International Organization for Standardization Standard ISO 14520, Gaseous Fire-Extinguishing Systems-Physical Properties and System Design, Part 1 (General requirements) and Part 9 (HFC 227ea Extinguishant), First Edition	5611/5612		01 August 2000

FM APPROVALS
3022566

Title	FM Approvals Number	Class	Date
British Standards Institution and International Organization for Standardization Standard BS EN 13322-1, Transportable Gas Cylinders-Refillable Welded Steel Gas Cylinders-Design and Construction, Part 1 (Carbon Steel)	5611/5612		2003
European Union Council Directive 1999/36/EC on Transportable Pressure Equipment	5611/5612		29 April 2003
National Fire Protection Association NFPA 2001 Standard for Clean Agent Extinguishing Systems	5611/5612		2004 Edition
Underwriters' Laboratories, Inc. Standard UL 2166, Standard for Halocarbon Clean Agent Extinguishing System Units	5612		March 1999

- 1.6 **Listing:** The product will appear in Chapter 5 of the Fire Protection book of the FM Approval Guide in the Clean Agent Extinguishing Systems section, as listed in Appendix 1.

II DESCRIPTION

- 2.1 This fire extinguishing system is used to protect total flooding hazards, which can be either normally occupied or unoccupied. Total flooding protection is applicable to enclosed special hazards such as rooms or spaces containing flammable liquids, electrical equipment, records, or other storage where a fire could be extinguished by a clean agent fire extinguishing gas. The environment where the agent storage cylinders/valves are located shall be controlled to maintain temperatures consistently within this range to ensure proper delivery of extinguishing concentrations to all protected spaces. When agent storage temperatures are between 32 and 130°F (0 to 54°C), a single nozzle or a balanced piping configuration may be used to protect a single hazard, only. All other piping configurations require the agent storage temperature to be at 70°F ± 10°F (21.1°C ± 5.5°C). For all systems, the hazard temperature can range between 10 and 200°F (-12 and 93°C), in compliance with NFPA 2001, with the mass of the agent required for hazard protection increased or decreased relative to the temperature difference from 70°F (21°C).
- 2.2 The extinguishing agent is identified in the ISO 14520 standards and NFPA 2001 as HFC-227ea, 1,1,1,2,3,3,3 - heptafluoropropane, (CF₃CHF₂CF₃), and by the trade name FM-200[®]. This clean agent is manufactured by Great Lakes Chemical Company, West Lafayette, IN. It is FM Approved as a component for clean agent fire extinguishing systems which have been expressly tested with this agent. This agent is superpressurized with nitrogen to a pressure of 360 psi (25 bar) at 70°F (21°C) for use in these systems. The following reports document the component Approval of the FM-200[®] extinguishing agent and therefore supplement this Report.

Project	Report Title	Report Date
0X8A7.AF	System Component Approval of FM-200 , (Chemically Identified as 1,1,1,2,3,3,3 – Heptafluoropropane) Total Flooding Fire Extinguishing Agent	01 April 1994

FM APPROVALS
3022566

Project	Report Title	Report Date
3009990	Class A & B Fire Tests of FM-200® Clean Extinguishing Agent (Contract Test Report)	30 April 2002

- 2.3 The minimum extinguishing concentration for Class A (wood and most plastics) combustible surface fires is 5.2 percent, requiring a 6.25 percent minimum design concentration, based upon the NFPA 2001 required 1.2 design factor. ISO 14520 systems require a minimum 6.76 percent based upon the required 1.3 design factor. Class B (normal heptane) fire cup burner minimum extinguishing concentration is 6.6 percent, requiring an 8.58 percent minimum design calculation, based upon the required 1.3 design factor. The minimum design concentration for all other Class B flammable liquid fires shall be held to 1.3 times the established cup burner value.
- 2.4 The attached Design, Installation, Operation, and Maintenance Manual (part number 59812-422), Issue C, dated November 2004, describes the system.
- 2.5 Systems are designed in accordance with Kidde Fire Protection GX20 Series Flow Calculation Software Version GX3.03.
- 2.6 The specific modifications to be performed by Kidde Fire Protection are limited to the following:
 - 2.6.1 The components unique to the GX-20 system are tabulated in Section VIII.
 - 2.6.2 The nozzles, some hoses, and mounting brackets are sourced locally by Kidde Fire Protection.
 - 2.6.3 The storage cylinders are produced by Kidde-Fenwal's supplier, Manchester Tank and Equipment Company, of Franklin, Tennessee U.S.A., but are manufactured to address European compliance requirements for Transportable Pressure Equipment, rather than U.S. Department of Transportation requirements.
 - 2.6.4 The cylinders are assembled, filled with FM-200®, superpressurized with nitrogen, stabilized, and leak-tested in accordance with Kidde-Fenwal procedures by Kidde Fire Protection personnel in their High Bentham, Lancashire, United Kingdom facility.

III EXAMINATIONS AND TESTS

- 3.1 Because of the limited range of modifications conducted by Kidde Fire Protection, only limited testing was required. The locally sourced nozzles were hydrostatically tested and the hoses were examined for low temperature flexibility and also hydrostatically tested. All tests were conducted at the FM Approvals Hydraulics Laboratory in West Glocester, Rhode Island. In addition, the design, installation, operation, and maintenance manual, design software, and agent storage container designs were reviewed. All data is on file at FM Approvals along with other documents and correspondence applicable to this examination.
- 3.2 Hydrostatic tests of each pipe size nozzle blank were conducted to 2000 psi (138 bar) for one minute with no failures.
- 3.3 Flexure tests of the B6793-760, B6793-761, B6793-763, and D7715-037 hoses were conducted. The samples were conditioned at 32°F (0°C) for 24 hours then bent through 90 degrees at their minimum bending radii. No cracking or other damage was visible. Subsequently, the samples

FM APPROVALS
3022566

were allowed to warm to room temperature and were hydrostatically pressurized to 2000 psi (138 bar) for one minute with no failure.

- 3.4 The agent storage containers design calculations were reviewed against the ISO 14520-1 & -9 standard requirements. Design is per prEN 13322-1 and EU Council Directive 1999/36/EC on transportable pressure equipment. The calculations verified compliance of the designs to these standards. Certificates of compliance and test for sample cylinders of each size from TUV Rheinland were submitted to confirm their compliance to the design. Since TUV Rheinland is recognized by FM Global as a third party certifier of pressure vessels, this documentation was considered adequate without witnessed testing.

IV MARKING

- 4.1 The following information appears on the agent storage vessels and meets Approval requirements:

- Manufacturer's name and address.
- Part number
- Agent identity
- Minimum and maximum storage temperatures
- Appropriate cautions
- The FM Approval Mark

- 4.2 Valves and other actuation components carry appropriate manufacturer identification, size, pressure, and electrical rating information.

- 4.3 Nozzles are marked with orifice size and part number.

V REMARKS

- 5.1 Compatible FM Approved controls, detectors, and releasing devices must be used and must be specifically Approved for the control of fixed extinguishing systems.
- 5.2 When disconnecting a fixed fire extinguishing system for testing or maintenance, it must be isolated mechanically from the control system by means of switches or similar devices and not solely by programming a control via software or firmware.
- 5.3 Installations of these systems are subject to the limitations specified in this report to remain within the scope of the Approval and are subject to FM Global acceptance of plans prior to installation in FM Global insured property. Required design concentrations may vary, depending upon FM Global guidelines or local jurisdictional rules for the hazard to be protected. Adequate and appropriate primary protection for the building, such as automatic sprinklers, is usually required irrespective of the installation of a clean agent system. Generally, clean agent extinguishing systems are not accepted as primary protection for a building.
- 5.4 Systems must be designed in accordance with Kidde Fire Protection GX20 Series Flow Calculation Software Version GX3.03 and installed per their Design, Installation, Operation, and Maintenance Manual (part number 59812-422), Issue C, dated November 2004. The guidelines established by ISO 14520-1, ISO 14520-9, and NFPA 2001 shall be followed unless design and application are further constrained by the Approval limitations specified in this report and the system listing.

FM APPROVALS
3022566

- 5.5 Approval is limited to systems using factory-filled agent storage containers. The manufacturer may request FM Approval of alternate filling sites. Such sites shall be listed in the FM Approval Guide only after successful evaluation by FM Approvals and will be subject to ongoing audit surveillance. The manufacturer shall provide such sites with current filling instructions and provide any necessary training to site personnel on an ongoing basis for the site's FM Approval to remain valid. This is required to ensure that only properly filled cylinders are used in FM Approved systems.
- 5.6 FM-200 is a vaporizing halocarbon liquid and achieves extinguishment by absorbing heat when vaporizing. While it is acceptable for use in occupied spaces at the design extinguishing concentrations, maximum personnel safety requires that the area should always be evacuated prior to system discharge. For this reason, all systems must be designed with both predischage alarms and discharge time delays.

VI FACILITIES AND PROCEDURES AUDIT

The manufacturing sites for these systems are Kidde Fire Protection, High Bentham, Lancaster UK and Kidde-Fenwal, Ashland, Massachusetts, a sister company. These sites are currently regularly audited as a part of the FM Approvals facilities and procedures audit (F&PA) program. The addition of these systems represents no new technology which would require a special audit to evaluate the manufacturing controls.

VII MANUFACTURERS RESPONSIBILITIES

- 7.1 Documentation considered critical to this Approval is on file at FM Approvals and listed in the Documentation File, Section VIII of this report. No changes of any nature shall be implemented unless notice of the proposed change has been given and written authorization obtained from FM Approvals. The Approved Product Revision Report, Form 797, shall be forwarded to FM Approvals as notice of proposed changes.
- 7.2 It is the manufacturer's responsibility to keep aware of all EU, ISO, NFPA, local jurisdictional, and FM Approvals requirements, and any changes thereto, which may affect the acceptance and use of these systems.

VIII DOCUMENTATION

The following drawings describe these systems and are filed under Project 3022566.

Drawing	Title	Revision
E7763-101-01-EU	GCV 40 Valve & 5 L Container Assembly 25 bar (HFC227ea)	3
E7763-102-01-EU	GCV 40 Valve & 8 L Container Assembly 25 bar (HFC227ea)	3
E7763-103-01-EU	GCV 40 Valve & 16 L Container Assembly 25 bar (HFC227ea)	3
E7763-104-01-EU	GCV 40 Valve & 28 L Container Assembly 25 bar (HFC227ea)	3
E7763-105-01-EU	GCV 40 Valve & 51 L Container Assembly 25 bar (HFC227ea)	3
E7763-106-05-EU	GCV 50 Valve & 81 L Container Assembly 25 bar (HFC227ea)	4
E7763-107-02-EU	GCV 50 Valve & 81 L Container Assembly 25 bar (HFC227ea)	3
E7763-108-01-EU	GCV 50 Valve & 142 L Container Assembly 25 bar (HFC227ea)	4

FM APPROVALS
3022566

Drawing	Title	Revision
E7763-109-01-EU	142 L Container Assembly c/w GC50 Valve & Liquid Level Indicator 25 bar (HFC227ea)	3
E7763-110-01	GCV 65 Valve & 243 L Container Assembly 25 bar (HFC227ea)	6
E7763-110-05	243 L Container and 3 inch Valve	4
E7763-110-05-EU	243 L Container and 3 inch Valve	2
E7763-111-01	GCV 65 Valve & 243 L Container Assembly 25 bar (HFC227ea)	6
E7763-111-05	243 L Container and 3 inch Valve with Liquid Level Indicator	4
E7763-111-05-EU	243 L Container and 3 inch Valve with Liquid Level Indicator	2
E7763-112-01	368 L Container and 3 inch Valve	4
E7763-112-01-EU	368 L Container and 3 inch Valve	2
E7763-113-01	368 L Container and 3 inch Valve with Liquid Level Indicator	4
E7763-113-01-EU	368 L Container and 3 inch Valve with Liquid Level Indicator	2
B6792-724	5 litre Cylinder (Pi marked)	C
1-B6792-725	8 litre Cylinder (Pi marked)	C
1-B6792-726	16 litre Cylinder (Pi marked)	D
1-B6792-727	28 litre Cylinder (Pi marked)	D
1-B6792-728	51 litre Cylinder (Pi marked)	D
1-B6792-734	81 litre Cylinder (Pi marked)	A
1-B6792-735	142 litre Cylinder (Pi marked)	D
1-WK-296096-000	243 L Container	C
1-B6792-731	243 litre Cylinder (Pi marked)	D
1-B6792-722	243 litre Cylinder (DOT)	A
1-B6792-732	368 litre Cylinder (Pi marked)	D
1-B6792-723	368 litre Cylinder (DOT)	A
1-B6793-794	Burst Disc Assembly (CE marked)	1
C1961-118	Tube - Syphon 5L	1
C1961-119	Tube - Syphon 8L	1
C1961-120	Tube - Syphon 16L	1
C1961-121	Tube - Syphon 28L	1
C1961-107	Tube - Syphon 51L	1
C1961-116	Tube - Syphon 81L	2
C1961-105	Tube - Syphon 142L	2
C1961-104	Syphon tube	B
C1961-122	Tube - Syphon (243L)	1
C1961-123	Tube - Syphon 368L	1
C2775-311	1 1/2 in. Adaptor Syphon tube	A
A7521-003	Loctite 083	1
50/21071	Loctite Activator	1
18712-002	Lubricant	1
C9135-811	Label - UL/FM Kidde	A
C9135-812	Label - UL/FM Kidde	A
C9157-701	Label - Valve	1
K62987	Plug	2
K97345	O Ring - Packing	1
B6793-760	Hose Assembly 1 1/2 in. NPT GX 20 FM200	2
B6793-761	Hose Assembly 2 in. NPT GX 20 FM200	2
B6793-763	Hose Assembly 2 1/2 in. NPT GX 20 FM200	1
D7715-037	Hose Flexible 3 in. NPT/Grooved	B
D7715-038	Hose Flexible 3 in. Grooved/Grooved	1

FM APPROVALS
3022566

Drawing	Title	Revision
K63497-02	Adaptor	4
K63497-03	Adaptor	4
K63497-04	Adaptor	4
C6331-103	Strap - Dia 178 Cylinder	A
C6331-104	Strap - Dia 229 Cylinder	A
C6331-105-02	Strap - Dia 324 Cylinder	A
C6331-122	Cradle - dia 324 Cylinder	A
C6331-123	Clamp - Front - Dia 324 Cylinder	A
C6331-106	Strap - Dia 406 Cylinder	A
C6331-124	Cradle - dia 406 Cylinder	A
C6331-125	Clamp - Front - Dia 406 Cylinder	A
C6331-107	Strap - Dia 559 Cylinder	A
C6331-126	Cradle - dia 559 Cylinder	A
C6331-127	Clamp - Front - Dia 559 Cylinder	A
C6331-121	Strap - Dia 610 Cylinder	A
C3333-301-21/99	Nozzle, Drilling Detail 180 deg, 1/2 inch BSP	2
C3333-301	Nozzle, Blank 180 deg, 1/2 inch BSP	3
C3333-302-21/99	Nozzle, Drilling Detail 180 deg, 3/4 inch BSP	2
C3333-302	Nozzle, Blank 180 deg, 3/4 inch BSP	3
C3333-303-21/99	Nozzle, Drilling Detail 180 deg, 1 inch BSP	2
C3333-303	Nozzle, Blank 180 deg, 1 inch BSP	3
C3333-304-21/99	Nozzle, Drilling Detail 180 deg, 1 1/4 inch BSP	2
C3333-304	Nozzle, Blank 180 deg, 1 1/4 inch BSP	4
C3333-305-21/99	Nozzle, Drilling Detail 180 deg, 1 1/2 inch BSP	3
C3333-305	Nozzle, Blank 180 deg, 1 1/2 inch BSP	4
C3333-306-21/99	Nozzle, Drilling Detail 180 deg, 2 inch BSP	3
C3333-306	Nozzle, Blank 180 deg, 2 inch BSP	4
C3333-307-21/99	Nozzle, Drilling Detail 360 deg, 1/2 inch BSP	2
C3333-307	Nozzle, Blank 360 deg, 1/2 inch BSP	3
C3333-308-21/99	Nozzle, Drilling Detail 360 deg, 3/4 inch BSP	2
C3333-308	Nozzle, Blank 360 deg, 3/4 inch BSP	3
C3333-309-21/99	Nozzle, Drilling Detail 360 deg, 1 inch BSP	2
C3333-309	Nozzle, Blank 360 deg, 1 inch BSP	3
C3333-310-21/99	Nozzle, Drilling Detail 360 deg, 1 1/4 inch BSP	2
C3333-310	Nozzle, Blank 360 deg, 1 1/4 inch BSP	4
C3333-311-21/99	Nozzle, Drilling Detail 360 deg, 1 1/2 inch BSP	3
C3333-311	Nozzle, Blank 360 deg, 1 1/2 inch BSP	4
C3333-312-21/99	Nozzle, Drilling Detail 360 deg, 2 inch BSP	3
C3333-312	Nozzle, Blank 360 deg, 2 inch BSP	4
C3333-328-21/99	Nozzle, Drilling Detail 180 deg, 1/2 inch BSP	1
C3333-328	Nozzle, Blank 180 deg, 1/2 inch BSP	1
C3333-329-21/99	Nozzle, Drilling Detail 180 deg, 3/4 inch BSP	1
C3333-329	Nozzle, Blank 180 deg, 3/4 inch BSP	1
C3333-330-21/99	Nozzle, Drilling Detail 180 deg, 1 inch BSP	1
C3333-330	Nozzle, Blank 180 deg, 1 inch BSP	1
C3333-331-21/99	Nozzle, Drilling Detail 180 deg, 1 1/4 inch BSP	1
C3333-331	Nozzle, Blank 180 deg, 1 1/4 inch BSP	1
C3333-332-21/99	Nozzle, Drilling Detail 180 deg, 1 1/2 inch BSP	1
C3333-332	Nozzle, Blank 180 deg, 1 1/2 inch BSP	1

FM APPROVALS
3022566

Drawing	Title	Revision
C3333-333-21/99	Nozzle, Drilling Detail 180 deg, 2 inch BSP	1
C3333-333	Nozzle, Blank 180 deg, 2 inch BSP	1
C3333-334-21/99	Nozzle, Drilling Detail 360 deg, 1/2 inch BSP	1
C3333-334	Nozzle, Blank 360 deg, 1/2 inch BSP	1
C3333-335-21/99	Nozzle, Drilling Detail 360 deg, 3/4 inch BSP	1
C3333-335	Nozzle, Blank 360 deg, 3/4 inch BSP	1
C3333-336-21/99	Nozzle, Drilling Detail 360 deg, 1 inch BSP	1
C3333-336	Nozzle, Blank 360 deg, 1 inch BSP	1
C3333-337-21/99	Nozzle, Drilling Detail 360 deg, 1 1/4 inch BSP	1
C3333-337	Nozzle, Blank 360 deg, 1 1/4 inch BSP	1
C3333-338-21/99	Nozzle, Drilling Detail 360 deg, 1 1/2 inch BSP	1
C3333-338	Nozzle, Blank 360 deg, 1 1/2 inch BSP	1
C3333-339-21/99	Nozzle, Drilling Detail 360 deg, 2 inch BSP	1
C3333-339	Nozzle, Blank 360 deg, 2 inch BSP	1

IX CONCLUSION

The system described in Appendix 1 meets FM Approvals requirements. Since a duly signed Master Agreement is on file for this manufacturer, Approval is effective the date of this report.

EXAMINATION AND TESTING BY:

Armand V. Brandao

PROJECT DATA RECORD:

Project 3022566

ORIGINAL TEST DATA:

PDRs 1Y5A2.AF, 3018461, & 3022566

ATTACHMENTS:

Appendix 1, FM Approval Guide Listing, Manufacturer's Design, Installation, Operation, and Maintenance Manual, Part Number 59812-422

REPORT BY:



Armand V. Brandao, P.E.
Senior Engineer
Hydraulics Group

REPORT REVIEWED BY:



David B. Fuller
Technical Team Manager
Hydraulics Group

FM APPROVALS
3022566

Appendix 1
Approval Guide Listing

Kidde Fire Protection, Thame Park Road, Thame, Oxfordshire OX9 3RT, United Kingdom

Kidde Fire Protection GX-20 25 bar engineered, unbalanced fire extinguishing system using FM-200® clean agent. After filling, agent storage containers are superpressurized with nitrogen to 360 psi (25 bar) at 70°F (21°C). Automatic or manual (local and remote) operation. Suitable for use where the ambient storage temperature is between 32 and 130°F (0 and 54°C). Reference the Design, Installation, Operation, and Maintenance Manual 59812-422, Issue C, dated November 2004 for restrictions based upon the application. 180 and 360° nozzles are available.

Systems must be designed per Kidde Fire Protection GX20 Series Flow Calculation Software, Version GX3.03.

Notes:

1. FM Approvals validation of the flow calculation software for unbalanced configurations with multiple hazards is based upon agent storage temperatures between 60 and 80°F (15 and 27°C). Therefore, the environment where the agent storage cylinders/valves are located shall be controlled to maintain temperatures consistently within this range to ensure proper delivery of extinguishing concentrations to all protected spaces. When agent storage temperatures are between 32 and 130°F (0 to 54°C), a single nozzle or a balanced piping configuration may be used to protect a single hazard, only. All other piping configurations require the agent storage temperature to be at 70°F ± 10°F (21.1°C ± 5.5°C). For all systems, the hazard temperature can range between 10 and 200°F (-12 and 93°C), in compliance with NFPA 2001, with the mass of the agent required for hazard protection increased or decreased relative to the temperature difference from 70F (21°C).
2. FM Approval is based upon factory-filled FM-200® storage containers.
3. The extinguishing agent is FM-200® fluid, chemically identified as 1,1,1,2,3,3,3 - heptafluoropropane or CF₃CHF₂CF₃. NFPA 2001 identifies this agent as HFC-227ea.

Part Name	Part No.
<u>Agent Storage Containers</u>	
5 L Cylinder with GCV 40 valve	E7763-101-01-EU
8 L Cylinder with GCV40 valve	E7763-102-01-EU
16 L Cylinder with GCV40 valve	E7763-103-01-EU
28 L Cylinder with GCV40 valve	E7763-104-01-EU
51 L Cylinder with GCV40 valve	E7763-105-01-EU
81 L Cylinder with GCV50 valve	E7763-106-05-EU
81 L Cylinder with GCV50 valve and LLI	E7763-107-02-EU
142 L Cylinder with GCV50 valve	E7763-108-01-EU
142 L Cylinder with GCV50 valve and LLI	E7763-109-01-EU
243 L Cylinder with GCV65 valve	E7763-110-01
243 L Cylinder with GCV80 Valve	E7763-110-05
243 L Cylinder with GCV65 valve and LLI	E7763-111-01
243 L Cylinder with GCV80 valve and LLI	E7763-111-05
243 L Cylinder with GCV80 valve	E7763-110-05-EU
243 L Cylinder with GCV80 valve and LLI	E7763-111-05-EU
368 L Cylinder with GCV80 valve	E7763-112-01
368 L Cylinder with GCV80 valve	E7763-112-01-EU
368 L Cylinder with GCV80 valve and LLI	E7763-113-01
368 L Cylinder with GCV80 valve and LLI	E7763-113-01-EU

Cylinder Support Components

FM APPROVALS

3022566

Appendix 1
Approval Guide Listing

Part Name	Part No.
Cylinder Strap, all cylinder sizes	C6331-103, -104, -105-02, -106, -107, & -121
Wall Mounting Bracket, 5, 8, 16, 28 L	D1162-001 through -004
Cylinder Cradle, 51, 81, 142, & 243 L	C6331-122, -124, & -126
Front Clamp, 51, 81, 142, & 243 L	C6331-123, -125, & -127
<u>Discharge Connectors</u>	
1-1/2 in. Outlet Hose, 24 in. long (GCV40)	B6793-760
2 in. Outlet Hose, 31 in. long (GCV50)	B6793-761
2 in. Elbow Check Valve	B6793-762
2 in. Swing Check Valve	B6793-805
2-1/2 in. Outlet Hose, 48 in. long (GCV65)	B6793-763
2-1/2 in. Elbow Check	B6793-764
3 in. Outlet Hose, 50 in. long (GCV80), Groove x NPT	D7715-037
3 in. Outlet Hose, 50 in. long (GCV80), Groove x Groove	D7715-038
3 in. Swing Check Valve	B6793-869
GCV40 Outlet to BSP Pipe Adapter	K63497-02
GCV50 Outlet to BSP Pipe Adapter	K63497-03
GCV65 Outlet to BSP Pipe Adapter	K63497-04
<u>Discharge Control Components</u>	
Electric Control Head, (24 V dc 2 A)	B6793-701
Electric and Cable Control Head, (24 V dc)	B6793-702
Electric and Cable Control Head, explosion proof (24 V dc)	B6793-703
Cable Operated Control Head	B6793-704
Lever Operated Control Head	B6793-705
Lever and Pressure Operated. Control Head	B6793-706
Pressure Operated Control Head	B6793-707
Pressure Operated Control Head, Stackable	B6793-708
Electric Control Head, Stackable (24 V dc 0.2 A), WARNING: FOR GX20 VALVES, ONLY	B6793-709
Nitrogen Pilot Cylinder (1.77 L)	B6793-720
Pilot Cylinder Mounting Bracket	B6793-721
Standard Discharge Pressure Switch	B6793-731
Pressure Switch, explosion proof	B6793-732
Pressure Trip	B6793-733
Safety Outlet, 3/4 in. NPT	B6793-740
Master Cylinder Adapter Kit	B6793-770
22 in. (559 mm) Pilot Hose	B6793-771
30 in. (762 mm) Pilot Hose	B6793-772
Male Straight Adapter, Hose to 1/8 in. NPT	B6793-773
Male Elbow Adapter, Hose to 1/8 in. NPT	B6793-774
Male Branch Tee, Hose to 1/8 in. NPT	B6793-775
Cable Manual Pull Box, Break Glass	B6793-782
Corner Pulley, Watertight	B6793-783
Corner Pulley, 1/2 in. EMT, Standard	B6793-784
1/16 in. cable	B6793-785
Check Valve, 1/4 in.	B6793-786

FM APPROVALS
3022566

Appendix 1
Approval Guide Listing

Part Name	Part No.
Main to Reserve Transfer Switch	B6793-790
Check Valve, 1/2 in. NPT	B6793-806
Check Valve, 3/4 in. NPT	B6793-807
Check Valve, 1 in. NPT	B6793-808
Check Valve, 1-1/4 in. NPT	B6793-809
Check Valve, 1-1/2 in. NPT	B6793-810
Check Valve, 2 in.	B6793-811
Check valve, 3 in. NPT	B6793-812
Electric Control Head, explosion proof (24 V dc)	B6793-859
Cylinder Contents Supervisory Pressure Switch, GCV80 valve only	B6793-908
Cylinder Contents Supervisory Pressure Switch, GCV40, GCV50, & GCV65 valves	06-118262-001
<u>Nozzles</u>	
180° Nozzle, 1/2 in., BSP	C3333-301-22 through -37
180° Nozzle, 3/4 in., BSP	C3333-302-21 through -39
180° Nozzle, 1 in., BSP	C3333-303-22 through -41
180° Nozzle, 1-1/4 in., BSP	C3333-304-21 through 43
180° Nozzle, 1-1/2 in., BSP	C3333-305-21 through -42
180° Nozzle, 2 in., BSP	C3333-306-21 through -41
360° Nozzle, 1/2 in., BSP	C3333-307-23 through -41
360° Nozzle, 3/4 in., BSP	C3333-308-22 through -41
360° Nozzle, 1 in., BSP	C3333-309-24 through -44
360° Nozzle, 1-1/4 in., BSP	C3333-310-21 through -46
360° Nozzle, 1-1/2 in., BSP	C3333-311-21 through -44
360° Nozzle, 2 in., BSP	C3333-312-23 through 43
180° Nozzle, 1/2 in., NPT	C3333-328-22 through -37
180° Nozzle, 3/4 in., NPT	C3333-329-21 through -39
180° Nozzle, 1 in., NPT	C3333-330-22 through -41
180° Nozzle, 1-1/4 in., NPT	C3333-331-21 through-43
180° Nozzle, 1-1/2 in., NPT	C3333-332-21 through -42
180° Nozzle, 2 in., NPT	C3333-333-21 through -41
360° Nozzle, 1/2 in., NPT	C3333-334-23 through -41
360° Nozzle, 3/4 in., NPT	C3333-335-22 through -41
360° Nozzle, 1 in., NPT	C3333-336-24 through -44
360° Nozzle, 1-1/4 in., NPT	C3333-337-21 through -46
360° Nozzle, 1-1/2 in., NPT	C3333-338-21 through -44
360° Nozzle, 2 in., NPT	C3333-339-23 through -43
<u>Manuals</u>	
GX20™ FM-200® Fire Suppression System Owners Manual	59812-419
GX20™ Engineered FM-200® Fire Suppression System Design, Installation, Operation, and Maintenance Manual	59812-422
<u>Warning Labels</u>	
Entrance Label Manual When Occupied	K63499-03

FM APPROVALS
3022566

Appendix 1
Approval Guide Listing

Part Name	Part No.
Entrance Label: Caution Label: Manual Control Point	K63499-04 K63499-05



GX-20 Engineered FM-200 Fire Suppression System

DESIGN, INSTALLATION, OPERATION AND MAINTENANCE MANUAL

Part Number: 59812-422
November 2004

Kidde Fire Protection,
Thame Park Road,
Thame,
Oxfordshire,
OX9 3RT, UK
Tel: +44 (0) 1844 265003
Fax: +44 (0) 1844 265156

	Initials	Date	Signature
Prepared by:	MN/LJ/DS	8.04	
Checked by:	MN		
Checked by:	DS		
Released by:	LJ		

PROPRIETARY RIGHTS NOTICE

This document and the information that it contains are the property of Kidde Fire Protection Services Ltd. The information contained in this manual is believed to be correct in light of the latest data available.

Rights to duplicate or otherwise copy this document and rights to disclose the document and the information that it contains to others and the right to use the information contained therein may be acquired only by written permission signed by a duly authorised officer of Kidde Fire Protection Services Ltd.

© Copyright 2004 Kidde Fire Protection Services Ltd

AMENDMENT INCORPORATION RECORD		
Amendment Number	Brief Description of Content	Name of Person Incorporating Amendment
1	Safety Bulletin 1 SUBJECT: SAFE CYLINDER HANDLING PROCEDURES	Kidde Fire Protection
2	Safety Bulletin 2 SUBJECT: SAFE CYLINDER HANDLING PROCEDURES FOR 25 BAR CYLINDERS	Kidde Fire Protection
3	Safety Bulletin 12-2004 ADDITIONAL REQUIREMENTS FOR RETURN OF CHARGED CYLINDERS TO KIDDE FIRE PROTECTION	Kidde Fire Protection
4		
5		
6		
7		
8		
9		
10		

AMENDMENT INCORPORATION RECORD		
Amendment Number	Brief Description of Content	Name of Person Incorporating Amendment
11		
12		
13		
14		
15		
16		
17		
18		
19		
20		

TABLE OF CONTENTS

Chapter		Page
1	INTRODUCTION	1-1
	1.1 FOREWORD	1-1
	1.2 INTRODUCTION	1-2
2	SYSTEM DESCRIPTION	2-1
	2.1 GENERAL	2-1
	2.2 EXTINGUISHING AGENT	2-2
	2.3 COMPONENT DESCRIPTIONS	2-4
	2.3.1 GX20 Cylinder/Valve Assemblies	2-4
	2.3.2 Liquid Level Indicators	2-6
	2.3.3 Cylinder Straps and Brackets	2-7
	2.3.4 Control Heads	2-7
	2.3.5 Cable Manual Pull Station, Surface	2-9
	2.3.6 Actuation Accessories	2-9
	2.3.7 Discharge Accessories	2-10
	2.3.8 Nozzles	2-11
	2.3.9 Other Accessories	2-12
	2.3.10 Detectors and Control Panel	2-13
3	DESIGN	3-1
	3.1 GENERAL	3-1
	3.2 DESIGN CRITERIA	3-1
	3.3 AGENT CONCENTRATION	3-3
	3.4 FM-200 QUANTITY	3-4
	3.5 ATMOSPHERIC CORRECTION	3-5
	3.7 INTEGRITY OF HAZARD	3-5
	3.8 AGENT STORAGE CONTAINERS	3-5
	3.9 OTHER COMPONENTS	3-7
	3.10 LAYOUT DRAWING	3-7
	3.11 NOZZLE LOCATION	3-7
	3.12 PIPE SIZE	3-11
	3.13 SOFTWARE LIMITS	3-11
	3.14 TEE FLOW SPLITS	3-13
	3.15 CORNER PULLEY & CABLE LIMITATIONS	3-14
	3.16 PRESSURE TRIP LIMITATIONS	3-15
	3.17 PRESSURE ACTUATION LIMITATIONS	3-15
	3.17.1 For cylinders close coupled using pressure from one master GX20 cylinder	3-15
	3.17.2 For cylinders NOT close coupled using pressure from one master GX20 cylinder	3-15

TABLE OF CONTENTS

Chapter		Page
	3.17.3 For cylinders NOT close coupled using pressure from a pilot nitrogen cylinder	3-16
	3.17.4 For cylinders close coupled using pressure from one nitrogen pilot cylinder	3-17
	3.17.5 Use of multiple nitrogen pilot cylinders	3-18
4	INSTALLATION	4-1
4.1	GENERAL	4-1
4.2	DISTRIBUTION PIPING AND FITTINGS	4-2
	4.2.1 Piping - General	4-2
	4.2.2 Pipe	4-2
	4.2.3 Pipe Joining	4-2
	4.2.4 Reductions	4-2
	4.2.5 Cleaning	4-3
	4.2.6 Threads	4-3
	4.2.7 Installation	4-3
	4.2.8 Fittings	4-3
4.3	DISCHARGE NOZZLES	4-4
4.4	PRESSURE ACTUATION LINES	4-4
4.5	VALVE OUTLET ADAPTOR	4-4
4.6	FLEXIBLE DISCHARGE HOSE	4-4
4.7	MASTER CYLINDER ADAPTOR KIT	4-6
4.8	GX20 CYLINDER/VALVE ASSEMBLIES	4-7
	4.8.1 Single Cylinder Systems	4-7
	4.8.2 Multiple Cylinder Systems; & main/reserve systems	4-7
	4.8.3 Multiple Cylinder Systems	4-8
	4.8.4 Multiple Cylinder Systems	4-9
	4.8.5 Multiple Cylinder Systems	4-10
4.9	CYLINDER STRAPS AND BRACKETS	4-11
4.10	ELECTRIC CONTROL HEADS	4-14
4.11	PRESSURE OPERATED CONTROL HEADS	4-16
4.12	ELECTRIC AND CABLE OPERATED CONTROL HEAD	4-16
4.13	CABLE OPERATED CONTROL HEAD	4-17
4.14	LEVER OPERATED CONTROL HEAD	4-18
4.15	NITROGEN CYLINDER AND MOUNTING BRACKET	4-18
4.16	DISCHARGE PRESSURE SWITCH	4-19
4.17	PRESSURE TRIP	4-19
4.18	MANUAL PULL STATION	4-19
4.19	SUPERVISORY PRESSURE SWITCH	4-20
4.20	POST INSTALLATION CHECK-OUT	4-23

TABLE OF CONTENTS

Chapter		Page
5	OPERATION	5-1
5.1	GENERAL	5-1
5.2	OPERATING PROCEDURES	5-1
	5.2.1 Automatic Operation	5-1
	5.2.2 Remote Manual Operation	5-1
	5.2.3 Local Manual Operation	5-1
5.3	POST FIRE OPERATION	5-2
5.4	CYLINDER RECHARGE	5-2
5.5	SPECIAL SYSTEM PRECAUTIONS	5-2
6	MAINTENANCE	6-1
6.1	GENERAL	6-1
6.2	PREVENTATIVE MAINTENANCE	6-2
6.3	INSPECTION PROCEDURES	6-2
	6.3.1 Weekly	6-2
	6.3.2 Monthly	6-2
	6.3.3 Weighing GX20 Cylinders	6-4
	6.3.4 Every 6 Months	6-8
	6.3.5 Every 2 Years	6-9
6.4	RETEST PROCEDURES	6-9
	6.4.1 Cylinders Continuously in Service Without Discharge	6-9
	6.4.2 Discharged Cylinders or Charged Cylinders That Are Transported	6-9
	6.4.3 Retest	6-10
	6.4.4 Flexible Hoses	6-10
6.5	SERVICE	6-10
	6.5.1 Cleaning	6-10
	6.5.2 Nozzle Service	6-10
	6.5.3 Repairs	6-10
6.6	REMOVING GX20 CYLINDERS	6-11
	6.6.1 Single Cylinder Systems	6-11
	6.6.2 Multiple Cylinder Systems	6-11
6.7	INSTALLING GX20 CYLINDERS	6-12
	6.7.1 Single Cylinder Systems	6-12
	6.7.2 Multiple Cylinder Systems	6-12
6.8	POST FIRE MAINTENANCE	6-13

TABLE OF CONTENTS

Chapter		Page
6.9	RECHARGING GX20 CYLINDERS	6-13
6.10	NITROGEN PILOT CYLINDER SERVICE AND MAINTENANCE	6-14
6.10.1	Hydrostatic Pressure Test	6-14
6.10.2	Replacement	6-14
6.10.3	Recharge	6-14
6.10.4	Installation	6-15
7	APPROVED SYSTEM COMPONENTS	
7.1.	APPROVED SYSTEM COMPONENTS	7-1
7.2	CONDITIONS OF SALE	7-11
 Appendices		
A	SAFETY BULLETINS	A-1
B	MATERIAL SAFETY DATA SHEETS	B-1

LIST OF ILLUSTRATIONS

Figure		Page
2-1	FM-200 Pressure/Temperature Curve	2-4
3-1	Nozzle Coverage	3-9
3-2	180° Nozzle Example	3-10
3-3	360° Nozzle Coverage	3-10
3-4	% of FM-200 In Pipe and Before First Tee	3-12
3-5	Acceptable Tee Flow Splits	3-14
3-6	Pressure Actuation Using Pressure From (1) Master GX20 Cylinder To Activate A Maximum Of (15) GX20 Cylinders Close Coupled	3-15
3-7	Pressure Actuation Using Pressure From (1) Master GX20 Cylinder (5 Cylinders Maximum Not Close Coupled)	3-16
3-8	Pressure Actuation Using Pressure From (1) Nitrogen Pilot Cylinder To Actuate Maximum of (15) GX20 Cylinders NOT Close Coupled	3-17
3-9	Pressure Actuation Using Pressure From (1) Nitrogen Pilot Cylinder To Actuate Maximum of (15) Close Coupled GX20 Cylinders	3-17
3-10	Multiple Pilot Nitrogen Actuation Cylinders	3-18
4-1	Flexible Hose Directly Into System Piping	4-5
4-2	Master Cylinder Adaptor Kit	4-6
4-3	Typical GX20 Cylinder Installation - Vertical Mounting	4-12
4-6	Cylinder Strap - Multiple Cylinders	4-13
4-7	Electric Control Head, Stackable	4-14
4-8	Electric Control Head	4-15
4-8.5	Electrical Control Head (suitable for use with GCV 80)	4-15
4-9	Pressure Operated Control Head	4-16
4-10	Electric Cable Operated Control Head	4-17
4-11	Supervisory Pressure Switch	4-20
4-12	Supervisory Pressure Switch electrical connections	4-21
6.05	Liquid Level Indicator	6-4
6-1	Flexible Tape Calibration Chart for 51 litre GX20 Cylinder	6-5
6-2	Flexible Tape Calibration Chart for 81 litre GX20 Cylinder	6-6
6-3	Flexible Tape Calibration Chart for 142 litre GX20 Cylinder	6-6
6-4	Flexible Tape Calibration Chart for 243 litre GX20 Cylinder	6-7
6-5	Flexible Tape Calibration Chart for 368 litre GX20 Cylinder	6-17
6-6	Nitrogen Pressure versus Temperature Data	6-15

LIST OF TABLES

Table	Page
2-1 FM-200 Physical Properties	2-3
2-2 Dimensions - GX20 Cylinder/Valve Assemblies for Vertical Installation Only	2-6
2-3 Fill Range - GX20 Cylinder/Valve Assemblies for Vertical Installation Only	2-6
2-6 Cylinder Pressure Gauge Calibration	2-6
2-7 Electric Control Heads	2-7
2-8 Electric and Cable Operated Control Heads	2-8
2-9 Explosion Proof Control Head	2-9
2-10 Check Valves Equivalent Lengths	2-10
3-1 FM-200 Fire Suppression Use Concentrations % v/v	3-3
3-2 FM-200 Total Flooding Concentration (w/v)	3-4
3-3 Atmospheric Correction Factor	3-5
3-4 Fill Range - GX20 Cylinder/Valve Assemblies for Vertical Installation Only	3-6
3-6 Maximum Nozzle Straight Line Distances	3-9
3-7 Pipe Size Estimation	3-11
3-7.5 15 Pipe Diameters	3-13
3-8 Corner Pulley and Cable Limitations	3-14
4-1 Flexible Hose Dimensions	4-3
6-1 Preventative Maintenance Schedule	6-2

PREFACE

For ease of identification, this manual shall refer to each cylinder by its nominal water capacity. The table below indicates these nominal water capacities and the actual minimum water capacity for each cylinder size.

Nominal Water Capacity	Part No.	Minimum Water Capacity of Cylinder/Valve Assy
5 litre	E7763-101	4.7 litre cylinder (vertical), complete with GCV40 valve
8 litre	E7763-102	8.1 litre cylinder (vertical), complete with GCV40 valve
16 litre	E7763-103	16.2 litre cylinder (vertical), complete with GCV40 valve
28 litre	E7763-104	28.3 litre cylinder (vertical), complete with GCV40 valve
51 litre	E7763-105	50.6 litre cylinder (vertical), complete with GCV40 valve
81 litre	E7763-106	81.0 litre cylinder (vertical), complete with GCV50 valve
81 litre	E7763-107	81.0 litre cylinder (vertical), complete with GCV50 valve and liquid level indicator
142 litre	E7763-108	141.6 litre cylinder (vertical), complete with GCV50 valve
142 litre	E7763-109	141.6 litre cylinder (vertical), complete with GCV50 valve and liquid level indicator
243 litre	E7763-110	242.7 litre cylinder (vertical), complete with GCV80 valve
243 litre	E7763-111	242.7 litre cylinder (vertical), complete with GCV80 valve and liquid level indicator
368 litre	E7763-112	368 litre cylinder (vertical), complete with GCV80 valve
368 litre	E7763-113	368 litre cylinder (vertical), complete with GCV80 valve and liquid level indicator

CHAPTER 1

INTRODUCTION

1.1 FOREWORD

This manual is written for those who design, install and maintain Kidde Fire Protection GX20 Engineered FM-200 Fire Suppression Systems.

IMPORTANT

Kidde Fire Protection assumes no responsibility for application of any system other than those addressed in this manual. The technical data contained herein is limited strictly for information purposes only. Kidde Fire Protection believes this data to be accurate, but it is published and presented without any guarantee or warranty whatsoever. Kidde Fire Protection disclaims any liability for any use that may be made of the data and information contained herein by any and all other parties.

The Kidde Fire Protection GX20 Engineered FM-200 Fire Suppression Systems are to be designed, installed, inspected, maintained, tested and recharged by qualified and trained personnel in accordance with the following:

- Standard of the National Fire Protection Association No. 2001, titled "Clean Agent Fire Extinguishing Systems".
- BS EN ISO 14520-1 and 9 Gaseous Fire Extinguishing Systems Physical Properties and System Design for HFC-227 ea extinguishant.
- All instructions, limitations, etc. contained in this manual.
- All information contained on the system container nameplate(s).
- Storage, handling, transportation, service, maintenance, recharge and test of agent storage containers shall be performed only by qualified and trained personnel in accordance with the information in this manual and the relevant compressed gas standards.
- Regulations imposed by the Authority Having Jurisdiction for the hazard to be protected.

Any questions concerning the information presented in this manual should be addressed to:

Kidde Fire Protection,
Thame Park Road,
Thame,
Oxfordshire,
OX9 3RT, UK
Tel: +44 (0)1844 265003

Fax: +44 (0)1844 265156

1.2 INTRODUCTION

Kidde Fire Protection GX-20 systems are listed by Underwriters Laboratories Inc. (UL), Loss Prevention Certification Board (LPCB) and approved by Factory Mutual (FM). These systems are designed for total flooding in accordance with NFPA 2001: "Standard on Clean Agent Fire Extinguishing Systems" and BS EN ISO 14520 Gaseous Fire Extinguishing Systems. These systems have been tested to limits established jointly by UL and FM. In any situation not specifically covered by this manual, the application and installation of the system must meet the requirements of the standards as stated. In any case, all installations must meet the requirements of the local Authority Having Jurisdiction.

The complexity of two-phase flow does not allow for any simple method of manual FM-200 calculation. For this reason, the flow calculations and design criteria described in this manual have been incorporated into the computer software programme. The calculations are based on conserving mass, energy and momentum in the pipe network. The routine calculates the flow in quasi-steady state steps from the initiation of the discharge to the final gas blow down.

The system designer must become thoroughly familiar with the Kidde Fire Protection Clean Agent Flow Calculation Program User's Guide, to determine the proper procedures for applying the input parameters to the program. The User's Guide can be found on the software installation CD, Part No. D3882-017. There are a number of limitations to these input parameters which must be observed if accurate results are to be obtained.

Kidde Fire Protection GX20 Engineered FM-200 Fire Suppression Systems combine an environmentally safe fire suppression agent, highly effective detection devices and specially developed components for fast agent discharge. The resulting rapid suppression of a fire reduces property damage and products of combustion to the lowest possible level. These systems are electrically, pressure and/or cable operated, with a normal design discharge time of less than 10 seconds. GX20 containers can be strategically located throughout a protected zone, eliminating expensive piping.

CHAPTER 2

SYSTEM DESCRIPTION

2.1 GENERAL

Kidde Fire Protection GX20 Engineered FM-200 systems are used to suppress fires in specific hazards or equipment located where an electrically non-conductive agent is required, where agent cleanup creates a problem, where extinguishing capability with low weight is a factor, and where the hazard is normally occupied. Kidde Fire Protection GX20 systems are intended to protect the following total flooding applications:

- Data processing facilities
- Telecommunications facilities
- Process control rooms
- High value medical facilities
- High value industrial equipment areas
- Libraries, museums, art galleries
- Anechoic chambers
- Flammable liquid storage areas

GX20 systems are designed to be suitable for the following classes of fire:

Energised electrical equipment
Class A - Surface types: wood or other cellulose-type material
Class B - Flammable liquids

For flammable gas applications the gas supply must be isolated prior to the extinguishant release.

For inerting applications please contact Kidde Fire Protection. GX20 systems are not designed for explosion suppression. For hazards which might pose the risk of explosion, or an explosive environment please contact Kidde Fire Protection.

For hazards beyond the scope described above, the designer must consult with Kidde Fire Protection and EN ISO 14520, NFPA 2001 on the suitability of FM-200 for the protection, necessary design concentrations and personnel exposure effects from that concentration.

FM-200 must not be specified where the following material may be present:

Pyrotechnic chemicals containing their own oxygen supply
Reactive metals - sodium, potassium, magnesium, titanium, uranium and plutonium.
Metal hydrides.

FM-200 is not suitable for local application systems, as this has not been tested to date.

Operating Temperature Range Limitations:

The operating temperature range for all components used in Kidde Fire Protection GX20 systems is: 0 to 54°C (32 to 130°F).

2.2 EXTINGUISHING AGENT

FM-200 (1,1,1,2,3,3,3 - heptafluoropropane) is a compound of carbon, fluorine and hydrogen ($\text{CF}_3\text{CH}_2\text{CF}_3$). It is colourless, odourless and electrically non-conductive. It suppresses fire by a combination of chemical and physical mechanisms without directly affecting the available oxygen. This allows personnel to see and breathe, permitting them to leave the fire area safely. FM-200 has acceptable toxicity for use in occupied spaces when used as specified in the United States Environmental Protection Agency (EPA) Significant New Alternatives Policy (SNAP) program rules. Although FM-200 is considered non-toxic to humans in concentrations necessary to extinguish most fires, certain safety considerations should be observed when applying and handling the agent. The discharge of FM-200 may create a hazard to personnel from the undecomposed agent itself and from the decomposition products which result when the agent is exposed to fire or other hot surfaces. Exposure to the agent is generally of less concern than is exposure to the decomposition products. Unnecessary exposure to the agent or the decomposition products should be avoided. For exposure restrictions relevant to where the system is operational consult the Authority Having Jurisdiction for that locality.

Toxicity

Unnecessary exposure to clean agents is to be avoided in accordance with the requirements of EN ISO 14520-1:2000, clause 5 and NFPA-2001. As such, upon operation of a system pre-discharge alarm, all personnel should immediately exit the protected space. In no case shall personnel remain in the room in which there is a fire. In the very unlikely instance where a clean agent system should discharge unexpectedly into an occupied room, all personnel should proceed in a clam and orderly manner to an exit and leave the room.

FM-200 has been evaluated for cardiac sensitisation through test protocols approved by the US EPA. The EPA's SNAP Program classifies FM-200 as acceptable for use as a total flooding agent in occupied spaces with specific limitations. Refer to the SNAP program rules for more information.

Decomposition

When FM-200 is exposed to temperatures over approximately 700 °C (1300 °F), products of decomposition (halogen acids) are formed. If the FM-200 is discharged in 10 seconds or less, causing rapid extinguishment of flames, the amount of by-products formed is minimal.

Cleanliness

FM-200 is clean, leaves no residue, thereby eliminating costly after-fire clean-up and keeping expensive "down-time" to a minimum. Most materials such as steel, stainless steel, aluminium, brass and other metals as well as plastics, rubber and electronic components are unaffected by exposure to FM-200.

Other Safety Considerations

The high pressure discharge of FM-200 from the system nozzle(s) can create noise loud enough to be startling. The high velocity discharge can be significant enough to dislodge objects located directly in the discharge path. Enough turbulence may be created in the enclosure to move unsecured paper and other light objects. Direct contact with the vapourising agent being discharged from the nozzle(s) will have a chilling effect on objects, and can cause frost-bite burns to the skin. The liquid phase vapourises rapidly when mixed with air, and limits the chilling hazard to the immediate vicinity of the nozzle(s). Although FM-200 is colourless, discharge into humid atmospheres may cause a reduction of visibility for a short time, due to fogging.

Storage

FM-200 is stored in steel GX20 containers at 25 bar at 21 °C (360 psig at 70 °F), as a liquid with nitrogen added to improve the discharge characteristics. When discharged, the FM-200 liquid vapourises at the discharge nozzles and is uniformly distributed as it enters the fire area.

Table 2.1 FM-200 Physical Properties

Molecular Weight	170.03
Freezing Point	-131°C (-204°F)
Boiling Point at 1 atm	-16.4°C (2.6°F)
Vapour Pressure	2.26 bar absolute @ 4.4°C (32.9 psia @ 40°F)
	4.57 bar absolute @25°C (66.4 psia @ 77°C)
	10.2 bar absolute @ 54°C (148.2 psia @ 130°F)
Critical Temperature	101.7°C (215.1 °F)
Critical Density	621 kg/m ³ (38.76 lb/ft ³)
Critical Pressure	29.0 bar absolute (422 PSIA)
Critical Volume	1.61 l/kg (0.0258 cu. ft/lb)
Specific Heat, saturated vapour at 25°C (77°F)	0.2633 kcal/kg °C (0.2633 Btu/lb °F)
Specific Heat, saturated vapour at 25°C (77°F)	0.1856 kcal/kg °C (0.1856 Btu/lb °F)
Specific Heat, saturated vapour at 1 atm, 25°C (77°F)	0.1734 kcal/kg °C (0.1734 Btu/lb °F)
Heat of vapourisation at boiling point	31.7 kcal/kg (57.0 Btu/lb)
Thermal conductivity, liquid at 25°C (77°F)	0.069 W/m °K (0.040 Btu/hr ft °F)
Thermal conductivity, vapour at 25°C (77°F)	0.012 W/m °K (0.0068 Btu/hr ft °F)
Viscosity, liquid at 25°C (77°F)	0.184 centipoise (0.000124 lbm/ft s)
Viscosity, vapour at 25°C (77° F)	0.0132 centipoise (0.00000887 lbm/ft s)
Surface tension at 25°C (77°F)	7.00 mN/m (7.00 dyn/cm)

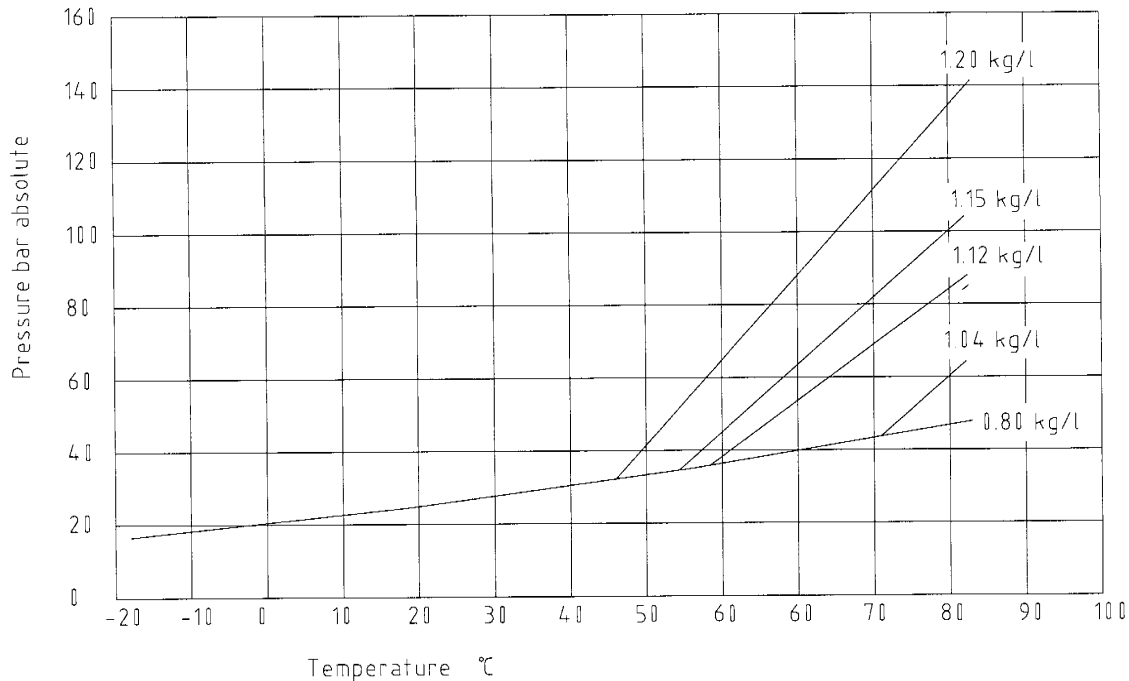

Figure 2.1 FM-200 Pressure/Temperature Curve

2.3 COMPONENT DESCRIPTIONS

Refer to Appendix C for component data sheets.

2.3.1 GX20 Cylinder/Valve Assemblies

FM-200 is stored in steel GX20 cylinders as a liquid super-pressurised with nitrogen to 25 bars at 21 °C (360 PSIG at 70 °F). The cylinder/valve assembly is equipped with: pressure gauge, burst disc, and a supervisory pressure switch connection for optional monitoring of the cylinder pressure. In addition, each cylinder/valve assembly is provided with an actuation port cap and a valve outlet protection cap that must be installed on the discharge outlet whenever a cylinder is not in service. These caps are added safety features designed to prevent uncontrolled accidental discharge that may result in serious injury or property damage. For transportation, these cylinders are also fitted with a valve protection cap in accordance with the Transportable Pressure Equipment Directive (TPED) 99/36/EC.

WARNING

THE SAFETY CAP MUST BE INSTALLED ON THE DISCHARGE OUTLET WHENEVER A CHARGED CYLINDER/VALVE ASSEMBLY IS NOT CONNECTED TO THE SYSTEM PIPING. FAILURE TO INSTALL THE SAFETY CAP COULD RESULT IN VIOLENT MOVEMENT OF THE CONTAINER IN THE EVENT OF INADVERTENT ACTUATION. FAILURE TO FOLLOW THESE INSTRUCTIONS COULD RESULT IN INJURY TO PERSONNEL AND DAMAGE TO PROPERTY.

2.3.1.1 Vertical Mount

Table 2.2 describes the 5 through 368 litre cylinder assemblies designed for vertical installation. The cylinders are equipped with a straight siphon tube and can only be mounted in a vertical (upright) position. The 81, 142, 243 & 368 litre cylinders can be provided with a liquid level indicator (LLI), at additional cost.

**Table 2.2 Dimensions - GX20 Cylinder/Valve Assemblies
for Vertical Installation Only**

Part No.	Valve	Nominal Volume (litre)	LLI	Nominal Height (mm)	Nominal Diameter (mm)
E7763-101-01-EU	GCV40	5	No	440	180
E7763-102-01-EU	GCV40	8	No	640	180
E7763-103-01-EU	GCV40	16	No	680	230
E7763-104-01-EU	GCV40	28	No	990	230
E7763-105-01-EU	GCV40	51	No	920	330
E7763-106-05-EU	GCV50	81	No	1340	330
E7763-107-02-EU	GCV50	81	Yes	1340	330
E7763-108-01-EU	GCV50	142	No	1490	410
E7763-109-01-EU	GCV50	142	Yes	1490	410
E7763-110-01	GCV65	243	No	1445	560
E7763-111-01	GCV65	243	Yes	1445	560
E7763-110-05-EU	GCV80	243	No	1470	560
E7763-111-05-EU	GCV80	243	Yes	1470	560
E7763-112-01-EU	GCV80	368	No	1780	610
E7763-113-01-EU	GCV80	368	Yes	1780	610

**Table 2.3 Fill Range - GX20 Cylinder/Valve Assemblies
for Vertical Installation Only**

Part No.	Nominal Volume (litre)	Fill Range (kg)	Equivalent Length w/o Flex Hose (m)	Equivalent Length w/ Flex Hose (m)
E7763-101-01-EU	5	3.0 to 4.5	18.84	19.81
E7763-102-01-EU	8	4.0 to 9.0	18.84	19.81
E7763-103-01-EU	16	8.0 to 18.0	18.84	19.81
E7763-104-01-EU	28	14.0 to 31.5	18.84	19.81
E7763-105-01-EU	51	24.5 to 56.5	18.84	19.81
E7763-106-05-EU	81	39.0 to 90.5	17.98	19.81
E7763-107-02-EU	81	39.0 to 90.5	17.98	19.81
E7763-108-01-EU	142	68.0 to 158.5	17.98	19.81
E7763-109-01-EU	142	68.0 to 158.5	17.98	19.81
E7763-110-01	243	117.0 to 272.0	17.98	19.81
E7763-111-01	243	117.0 to 272.0	17.98	19.81
E7763-110-05-EU	243	117.0 to 272.0	15.00	19.81
E7763-111-05-EU	243	117.0 to 272.0	15.00	19.81
E7763-112-01-EU	368	177.0 to 408.0	15.00	24.00
E7763-113-01-EU	368	177.0 to 408.0	15.00	24.00

2.3.1.3 Cylinder Pressure Gauge Calibration

The Kidde Fire Protection GX20 equipment listed herein is designed for an operating temperature range of: 0 to 54 °C (32 to 130 °F).

Table 2.6 shows the cylinder gauge pressure-temperature relationship based on a maximum fill density of 1.12 kg/l (70 lbs./ft³).

Table 2.6 Cylinder Pressure Gauge Calibration

°C	0	10	15	20	25	30	35	40	45	50	55
Bar	20.0	22.0	23.4	24.5	26.0	27.3	28.6	30.3	32.0	33.1	34.5

2.3.2 Liquid Level Indicators

The optional liquid level indicator consists of a hollow metal tube inserted into a special fitting located in the top of the 81, 142, 243 & 368 litre GX20 cylinder. The indicator is provided with a graduated tape designed to sense the position of a toroidal magnet encased within an internal float riding on the liquid surface. The graduations on the tape indicate the location of the liquid level within the cylinder.

2.3.3 Cylinder Straps and Brackets

Steel straps and brackets are used to mount the cylinders in a vertical position. Cylinder straps (P/Ns: C6331-103, -104, -105-02, -106, -107 and -121) are available for all sizes of cylinders. Wall brackets (P/Ns: D1162-001, -002, -003 and -004) are available for the 5, 8, 16 and 28 litre size cylinders. Cradles (P/Ns: C6331-122, -124 and -126) and front clamps (P/Ns: C6331-123, -125 and -127) are available for the 51, 81, 142 and 243 litre size cylinders.

2.3.4 Control Heads

2.3.4.1 Electric Control Heads

Part Nos. B6793-701 and B6793-709.

These control heads provide for electric actuation of the GX20 cylinder valve. The control head is operated electrically from the detection and control system, and/or a remote manual station. B6793-701 can also be operated locally with the manual lever on the electric control head. Control head, Part No. B6793-709, mounts directly on top of the GX20 cylinder valve (except GCV80). Its stackable design allows connection of a manual or pressure operated control head to the top of the control head.

All electric control heads are self-venting to prevent accidental system discharge in the event of a slow build up of pressure in a pilot line. A suitable control unit for use with the following control heads, shall be provided for supervision of the releasing and in addition, a 24 hour back-up power source shall be provided per ISO 14520-1 or NFPA requirements as required.

Table 2.7 Electric Control Heads

Part No.	Voltage	Amps	Solenoid Type
B6793-701	24 Vdc	2.0	Momentary
B6793-709*	24 Vdc	0.2	Continuous

WARNING

***THE STACKABLE CONTROL HEAD PART NUMBER B6793-709 SHALL NOT BE USED WITH THE GCV80 (3") VALVED CYLINDERS. THE CONTROL HEAD B6793-709 DOES NOT HAVE SUFFICIENT FORCE TO ACTIVATE THE GCV80 VALVE AND MAY RESULT IN A SYSTEM FAILURE. THE ELECTRICAL/MANUAL CONTROL HEADS (P/Ns B6793-859, B6793-701, B6793-787 AND 890149) MAY BE USED WITH THE GCV80 VALVE.**

ELECTRIC CONTROL HEAD, PART NO. B6793-709, IS DESIGNED FOR INSTALLATION DIRECTLY ON KIDDE GX20 CYLINDER /VALVES ONLY. THIS CONTROL HEAD MUST NOT BE INSTALLED ON ANY OTHER TYPE OF CYLINDER/VALVE, NITROGEN CYLINDER/VALVE, CARBON DIOXIDE CYLINDER /VALVE OR STOP (DIRECTIONAL) VALVE. INSTALLATION OF THIS CONTROL HEAD TO ANY OTHER DEVICE, E.G. PRESSURE OPERATED CONTROL HEAD, WILL RESULT IN FAILURE OF THE DEVICE TO OPERATE WHEN CONTROL HEAD IS ACTUATED.

2.3.4.2 Electric and Cable Operated Control Heads

Part Nos. B6793-702 and B6793-703.

These control heads provide for both electric actuation or remote cable operation. These control heads mount directly on the top of the GX20 cylinder valve or nitrogen pilot cylinder. The control head is operated remotely by an electrical signal from the detection system or electric manual pull station. The control head can also be operated mechanically from a remote cable operated manual pull station or locally using the manual lever on the control head.

All electric/cable operated control heads are self-venting to prevent accidental system discharge in the event of a slow build up of pressure in a pilot line. A suitable control unit for use with the following control heads, shall be provided for supervision of the releasing and in addition, a 24 hour back-up power source shall be provided per ISO 14520-1 or NFPA requirements as required.

Table 2.8 Electric and Cable Operated Control Heads

Part No.	Type	Voltage	Amps	Rating
B6793-702	Standard	24 Vdc	2.0 momentary	-
B6793-703	Explosion Proof	24 Vdc	1.65 continuous	33.0 W

2.3.4.3 Cable Operated Control Head

Part No. B6793-704.

This control head is used for systems designed for manual operation only. The cable operated control head mounts directly on top of the GX20 cylinder valve. The control head is operated remotely from a cable manual pull station or locally using the manual lever on the control head.

2.3.4.4 Lever Operated Control Head

Part No. B6793-705.

This type of control head is equipped with an operating lever secured in the closed position by a safety pull pin. By removing the safety pin, the lever can be manually rotated to the open position, thereby activating the cylinder or valve on which it is installed.

2.3.4.5 Pressure Operated Control Head

Part Nos. B6793-707, B6793-708 (stackable) and B6793-706 (pressure and lever operated).

The pressure operated control heads allow for pneumatic actuation of GX20 cylinders and are mounted directly on top of the GX20 cylinder valve. The pressure operated control heads are self-venting to prevent accidental system discharge in the event of a slow build up of pressure in the pilot line.

2.3.4.6 Explosion proof

Part No. B6793-859

The explosion proof control head has a continuous current draw, which must be accounted for at the control panel. The actuating pin latches in the released position and must be mechanically reset prior to rearming the system. Refer to the data sheet for ATEX and hazardous location classification details

Table 2. 9 Explosion proof control head

Part No.	Type	Voltage	Amps	Rating
B6793-859	Explosion Proof	24 Vdc	0.27 Continuous	18 Vdc @ 0.2 A to 30 Vdc @ 0.5 A

2.3.5 Cable Manual Pull Station, Surface Mounted

Part No. B6793-782.

The surface mounted remote cable manual pull station is a cable operated device. To operate the GX20 system, break the glass plate on the box using the attached hammer and pull the handle.

2.3.6 Actuation Accessories

2.3.6.1 Nitrogen Cylinder and Mounting Bracket

Part Nos. B6793-720 and B6793-721.

Gas pressure from a nitrogen cylinder is routed to the pressure operated control head mounted on each GX20 cylinder using pilot tubing. When the control head on the remote nitrogen cylinder is actuated, the GX20 cylinder will be activated, causing FM-200 to be discharged from the cylinder. The nitrogen cylinder can be used in single and multiple cylinder systems. Upon activation by a control head, gas pressure is routed from the nitrogen cylinder to pressure operated control heads mounted on each GX20 cylinder, resulting in complete system discharge.

2.3.6.2 Flexible Actuation Hoses

Part Nos. B6793-771 (559 mm long) and B6793-772 (762 mm long).

The flexible actuation hose is used in multiple cylinder systems. Pilot pressure is directed to a pressure operated control head on each GX20 cylinder valve using a 1/4-inch NB actuation hose.

2.3.6.3 Master Cylinder Adaptor Kit

Part No. B6793-770.

The master cylinder adaptor kit provides a means of connecting a flexible actuation hose to the master and slave cylinder/valve assemblies. The adaptor kit is provided with a cap intentionally chained to the adapter to prevent loss while in service and must not be removed from its chain. The kit also contains a pressure sensitive label that is placed on the cylinder valve after adaptor installation.

2.3.6.4 Tees, Elbows, and Adaptors

Part Nos. B6793-775 (tees), B6793-774 (elbow) and B6793-773, C3466-301, C3466-302 and C3496-304 (adaptors).

The tees, elbows and adaptors are used for interconnection of actuation hoses and pilot tubing to pressure operated control heads in multiple cylinder system installations.

2.3.7 Discharge Accessories

2.3.7.1 Check Valve (1/4 inch)

Part No. B6793-786.

1/4-inch NB check valves are installed in the pilot actuation line if more than one nitrogen actuator is used.

2.3.7.2 Flexible Discharge Hoses

Part Nos. B6793-760 (40 mm NB), B6793-761 (50 mm NB), B6793-763 (65 mm NB), D7715-037 (80mm NB grooved/NPT) and D7715-038 (80mm NB grooved/grooved)

FM-200 agent is routed from the GX20 cylinders to the discharge piping by a flexible 40, 50, 65 and 80mm NB. The hose is connected to the discharge outlet of the GX20 cylinder valve and terminates at the system piping or elbow check of the discharge manifold.

2.3.7.3 Valve Outlet Adaptors

Part Nos. K63497-02, K63497-03 and K63497-04.

A valve outlet adaptor is used to connect the cylinder valve outlet to the BSPT discharge piping when no flexible discharge hose is used.

Note: 3" valve cylinders are equipped with a roll-groove outlet. Use part nos B6782-177 and B6782-182 to connect to BSP or NPT piping networks respectively.

2.3.7.4 Manifold EL-checks

Part Nos. B6793-762 (50 mm NB EL-check) and B6793-764 (65 mm NB EL-check).

Manifold EL-checks are installed at the discharge manifold in a multiple cylinder arrangement to allow removal of any GX20 cylinder from the manifold while still retaining a closed system. The 50 mm NB EL-check is used on the 5 through 142 litre cylinders and the 65 mm NB EL-check is used on the 243 litre cylinder with the GCV65 only.

CAUTION

Manifold EL-checks are not intended to be used as check valves in main/reserve systems.

2.3.7.5 Swing checks and Check Valves

Part Nos. B6793-869 (80 mm NB) and B6793-805 (50 mm NB)

Swing checks are installed at the discharge manifold for multiple cylinder arrangement to maintain a closed system.

A full range of check valves (1/2" to 3" NPT) are available. See data sheet (B6793-806 to -812).

Table 2.10 Check Valves, Equivalent Lengths

Part No.	Description	Pipe type	Equivalent Length / m
B6793-762	Elbow Check 50mm NB (2" NPT)	40 T & 40 W	4.88
B6793-764	Elbow Check 65mm NB (2.5" NPT)	40 T & 40 W	5.33
B6793-805	Swing Check 50mm NB (2" NPT)	40 T & 40 W	4.06
B6793-869	Swing Check 80mm NB (3" NPT)	40 T & 40 W	3.96
B6793-806	Check Valve 15mm NB (1/2" NPT)	40 T & 40 W	2.13
B6793-807	Check Valve 20mm NB (3/4" NPT)	40 T & 40 W	5.18
B6793-808	Check Valve 25mm NB (1" NPT)	40 T & 40 W	3.66
B6793-809	Check Valve 32mm NB (1 1/4" NPT)	40 T & 40 W	15.54
B6793-810	Check Valve 40mm NB (1 1/2" NPT)	40 T & 40 W	17.37
B6793-811	Check Valve 50mm NB (2" NPT)	40 T & 40 W	50.29
B6793-812	Check Valve 80mm NB (3" NPT)	40 T & 40 W	242.31

2.3.7.6 Pressure Operated Switches

Part Nos. B6793-731 and B6793-732

Pressure switches operate from system pressure upon discharge to energise or de-energise electrically operated equipment. Pressure switches may be used to shut down machinery and ventilation or to annunciate system discharge. Refer to the data sheet for ATEX and hazardous location classification details

2.3.7.7 Pressure Operated Trip

Part No. B6793-733.

Pressure trips are used to close off the hazard space upon system discharge. The trips, operated by system pressure, are designed to release self-closing units for doors, windows and dampers. The maximum load to be attached to a pressure trip is 45 kg, this is based on a minimum pressure of 6 bar at the pressure trip.

2.3.8 Nozzles**2.3.8.1 Discharge Nozzles**

Discharge nozzles are used to disperse FM-200 uniformly throughout the hazard area. Patterns are designed to direct discharged FM-200 away from the ceiling, thus minimising the possibility of disturbance to ceiling tiles and light fittings. Nozzles are available to discharge in either 180° or 360° patterns, depending on location. The nozzles are brass, with BSP female pipe threads (NPT nozzles are available on request).

2.3.9 Other Accessories

2.3.9.1 Corner Pulleys

Part Nos. B6793-783 (watertight applications) and B6793-784 (industrial applications). Corner pulleys are used to change direction of cable lines without binding to ensure smooth operation.

2.3.9.2.1 Supervisory Pressure Switch GCV40, 50 and 65

Part No. 06-118262-001

The cylinder supervisory pressure switch is intended to detect a fall in pressure in the FM-200 cylinder. The switch can be wired for either normally-open or normally-closed operation, depending on installation requirements. The supervisory pressure switch, Part No. 06-118262-001, can be installed on cylinders with GCV 40, 50 and 65 valves. If the pressure inside the cylinder falls below 21 bar (305psig), the switch contacts will transfer and invoke a “fault” signal at the control panel.

2.3.9.2.2 Supervisory Pressure Switch GCV80

Part No. B6793-908

The cylinder supervisory pressure switch is intended to detect a fall in pressure in the FM-200 cylinder. The switch can be wired for either normally-open or normally-closed operation, depending on installation requirements. The supervisory pressure switch, Part No. B6793-908, can be installed on cylinders with GCV80 valves only. If the pressure inside the cylinder falls below 21 bar (305psig), the switch contacts will transfer and invoke a “fault” signal at the control panel.

2.3.9.3 Main To Reserve Transfer Switch

Part No. B6793-790.

The main to reserve transfer switch is installed on systems having main and reserve cylinders. Placing the switch in either the MAIN or RESERVE position provides an uninterrupted fire protection capability during system maintenance or in the event of a system discharge.

2.3.9.4 Hydrostatic Test Adaptors

The hydrostatic pressure test adaptor is installed on the GX20 cylinder in place of the cylinder valve when the cylinder is to be hydrostatically pressure tested. For cylinder test requirements, refer to Section 6.4 of this manual.

2.3.9.5 Cylinder Recharge Adaptors

The recharge adaptor is installed in the cylinder discharge outlet during the cylinder charging procedure. This adaptor is used for refilling the cylinder with FM-200 agent and super-pressurising the cylinder with nitrogen.

Note: The GCV80 valve and associated cylinder (new style 243ltr and 368ltr) do not require a recharge adaptor. Recharge of these cylinders is achieved via the ½”NPT connection on the grooved fitting plate on the outlet port.

2.3.9.6 Cylinder Seating Adaptor

The seating adaptor is installed on the cylinder actuation port during the cylinder charging procedure. This adaptor is used for seating the valve assembly after charging and super-pressurization is complete.

2.3.10 Detectors and Control Panel

2.3.10.1 Detectors

Detectors (ionization), photoelectric, thermal, ultraviolet, ultraviolet/infra-red, etc.) installed for use in conjunction with Kidde Fire Protection GX20 systems shall be UL Listed, FM and/or LPCB Approved for the intended application.

2.3.10.2 Control Panel

The control panel used shall be UL Listed, FM and/or LPCB Approved for releasing device service and compatible with Kidde Fire Protection GX20 equipment.

CHAPTER 3

DESIGN

3.1 GENERAL

This chapter is intended for system designers and installers. It outlines the steps needed to design the system including the limitations imposed on the design by the system hardware.

System design is based on the requirements of standards BS EN ISO 14520 parts 1 & 9, NFPA 2001 (current editions) and the Authority Having Jurisdiction (AHJ).

3.2 DESIGN CRITERIA

The complexity of two-phase flow formulas does not allow for any simple method of manual FM-200 calculation. For this reason, the flow calculations and design criteria described in this manual have been programmed into the GX20 Clean Agent Flow Calculation program.

CAUTION

The Clean Agent Flow Calculation program is the only calculation method to be used with the Kidde GX20 equipment. No other calculation method is acceptable to Kidde Fire Protection.

The system designer must become thoroughly familiar with the Kidde Fire Protection Clean Agent Flow Calculation Program User's Guide, to determine the proper procedures for applying the input parameters to the program. The User's Guide can be found on the software installation CD, Part No. D3882-017. There are a number of limitations to these input parameters which must be observed if accurate results are to be obtained. Most of these limitations are in the program. However, there are certain restrictions that must be addressed by the system designer before applying the input data. This chapter describes the essential design parameters and design limitations which must be considered.

To design a Kidde Fire Protection GX20 Engineered FM-200 system, carry out the following steps.

1. **Perform a hazard analysis and survey of protected area.**
2. **Determine the design concentration required for the hazard.**
3. **Calculate the volume of the protected area.**
4. **Calculate FM-200 agent quantity to provide required design concentration at minimum expected ambient temperature in protected area.**

This information is given for estimating purposes only. The computer program calculates this information for the designer.

NFPA 2001 and the US Environmental Protection Agency Significant New Alternatives Policy (SNAP) list provide specific guidelines for the use of FM-200. The minimum design concentration for systems specified to NFPA 2001, total flooding applications is 6.25% v/v. For systems specified to BS EN ISO 14520, a minimum design concentration of 7.5% v/v should be used. For either specification a higher concentration may be required for the specific hazard being protected.

IMPORTANT

The agent required must be based on the lowest expected ambient temperature in the protected space. Care must be taken that the calculated concentration for normally occupied spaces at the highest expected ambient temperature in the space does not exceed the value for of 10.5% v/v per NFPA 2001.

Per NFPA 2001 and BS EN ISO 14520, FM-200 systems with design concentrations below the NOAEL (9% v/v) are permitted for use in occupied areas. FM-200 can be designed between 9% and 10.5% for a five minute exposure using the PBPK model. GX20 systems with design concentrations above the NOAEL are not permitted to be in automatic mode whilst occupied. Table 3.1 gives the minimum design concentrations for FM-200 with various fuels.

3.3 AGENT CONCENTRATION

Table 3.1 FM-200 Fire Suppression Design Concentrations
% v/v

Fuel	Cup burner (%v/v)	Design Conc. %v/v (cup burner + 30%)	Fuel	Cup burner (%v/v)	Design Conc. %v/v (cup burner + 30%)
Acetone	6.9	9.0	Hydraulic Fluid*	6.5	8.5
Acetonitrile	4.3	7.0	Hydraulic Oil*	5.9	7.7
t-Amyl Alcohol	7.3	9.5	Hydrogen	13.2	17.2
AV Gas*	6.5	8.5	Isobutyl Alcohol	7.6	9.9
Benzene	5.5	7.2	Isopropanol	7.5	9.8
n-Butane	6.6	8.6	JP4*	6.9	9.0
n-Butanol	7.6	9.9	JP5*	6.9	9.0
2 -Butoxyethanol	7.4	9.6	Kerosene*	7.4	9.6
2 -Butoxyethyl Acetate	6.9	9.0	Methane	5.5	7.2
n-Butyl Acetate	7.0	9.1	Methanol	10.4	13.5
Carbon Disulfide	11.8	15.4	2-Methoxyethanol	9.4	12.2
Chloroethane	6.3	8.2	Methyl Ethyl Ketone	7.4	9.6
Crude Oil*	6.5	8.5	Methyl Isobutyl Ketone	7.0	9.1
Cyclohexane	7.2	9.4	Mineral Spirits*	6.6	8.6
Cyclohexylamine	8.3	8.7	Morpholine	7.9	10.3
Cyclopentanone	7.4	9.6	Nitromethane	9.9	12.9
1,2 -Dichloroethane	5.8	7.6	n-Pentane	6.8	8.8
Diesel*	6.7	8.7	Propane	6.7	8.7
N,N -Diethylethanolamine	7.8	10.1	1-Propanol	7.7	10.0
Diethyl Ether	7.5	9.8	Propylene	6.2	8.1
Ethane	6.7	8.7	Propylene Glycol	8.6	11.2
Ethanol	8.3	10.8	Pyrrolidine	7.3	9.5
Ethyl Acetate	6.8	8.9	Tetrahydrofuran	7.4	9.6
Ethyl Benzene	6.3	8.2	Tetrahydrothiophene	6.6	8.6
Ethylene	8.4	10.9	Toluene	5.6	7.3
Ethylene Glycol	7.6	9.9	Toluene-2, 4-Diisocyanate	4.0	7.0
Gasoline*	6.9	9.0	Transformer Oil*	7.3	9.5
n-Heptane	6.7	8.7	Turbine Oil**	7.2	9.4
n-Hexane	6.9	9.0	Xylene	6.0	7.8
1-Hexene	5.8	7.6			

* General Guideline - MSDS Required to determine proper concentration

** Texaco R & O 32

Typical Class A hazards include surface burning type fires such as wood or other cellulose type materials.

For other fire risks please consult Kidde Fire Protection.

3.4 FM-200 QUANTITY

Table 3.2 FM-200 Total Flooding Concentration Factors (w/v)

Temp °C	Specific Volume kg/m ³	FM-200 Concentration % by Volume							
		6.25	7	7.5	8	9	10	11	12
0	0.1268	0.5258	0.5936	0.6388	0.6858	0.7800	0.8763	0.9748	1.0755
5	0.1294	0.5152	0.5816	0.6261	0.6719	0.7642	0.8586	0.9550	1.0537
10	0.1320	0.5051	0.5700	0.6140	0.6585	0.7490	0.8414	0.9360	1.0327
15	0.1347	0.4949	0.5589	0.6023	0.6457	0.7344	0.8251	0.9178	1.0126
20	0.1373	0.4856	0.5483	0.5910	0.6335	0.7205	0.8094	0.9004	0.9934
25	0.1399	0.4765	0.5382	0.5802	0.6217	0.7071	0.7944	0.8837	0.9750
30	0.1425	0.4678	0.5284	0.5697	0.6104	0.6943	0.7800	0.8676	0.9573
35	0.1450	0.4598	0.5190	0.5596	0.5996	0.6819	0.7661	0.8522	0.9402
40	0.1476	0.4517	0.5099	0.5499	0.5891	0.6701	0.7528	0.8374	0.9230
45	0.1502	0.4439	0.5012	0.5405	0.5790	0.6586	0.7399	0.8230	0.9000
50	0.1527	0.4366	0.4929	0.5314	0.5694	0.6476	0.7276	0.8093	0.8929
55	0.1553	0.4293	0.4847	0.5226	0.5600	0.6369	0.7156	0.7960	0.8782

To determine the weight of agent at minimum design concentrations for situations not given in Table 3.2, use the following equation:

$$W = (V/s) \times [c/(100-c)]$$

where;

W= agent weight required

V= volume of space to be flooded

s= specific volume of superheated FM-200 vapour

c= desired concentration, % v/v, in air at the temperature indicated.

The specific volume of superheated FM-200 vapour, s, may be approximated using the following equation;

$$\text{Specific Volume } S = 0.12693 + 0.00005131 T$$

Where: T = temperature in °C

NOTE: Concentrations from 6.25 to 9% v/v are for use in both occupied and non-occupied spaces. Concentrations higher than 9% are for use in automatic mode for non-occupied spaces only.

3.5 ATMOSPHERIC CORRECTION

Where the system is to be installed and may experience the effects of abnormal altitudes, consideration must be made for correction, refer to Table 3.3.

Table 3.3 Atmospheric Correction Factor

Altitude km (feet)	Enclosure Pressure mm Hg (psia)	Atmospheric Correction
-0.92 (-3000)	840 (16.25)	1.11
-0.61 (-2000)	812 (15.71)	1.07
-0.30 (-1000)	787 (15.23)	1.04
-0.00 (0)	760 (14.71)	1.00
-0.30 (1000)	733 (14.18)	0.96
-0.61 (2000)	705 (13.64)	0.93
-0.92 (3000)	678 (13.12)	0.89
-1.21 (4000)	650 (12.58)	0.86
-1.53 (5000)	622 (12.04)	0.82
-1.84 (6000)	596 (11.53)	0.78
-2.14 (7000)	570 (11.03)	0.75
-2.44 (8000)	550 (10.64)	0.72
-2.75 (9000)	528 (10.22)	0.69
-3.05 (10000)	505 (9.77)	0.66

3.7 DETERMINE INTEGRITY OF THE HAZARD.

Will additional agent be required to offset leakage of the agent from the hazard? If so, consult Kidde Fire Protection.

3.8 AGENT STORAGE CONTAINERS.

Operating Temperature Range

The Kidde Fire Protection GX20 equipment listed herein is designed to operate within a temperature range of 0 to 54°C (32 to 130°F). The Clean Agent Flow Calculation program is designed for 21°C cylinder operating temperature.

The cylinder operating temperature must be in the range of 16 to 27 °C (60 to 80 °F) for a single unbalanced system protecting two or more separate hazards. If the cylinder operating/storage temperature is outside this range, an insufficient quantity of FM-200 may be discharged from one or more discharge nozzles.

Containers must be located as near to the protected space as possible. Cylinder storage temperature range is between 0 to 54 °C (32 to 130 °F). Additional heating or cooling of the cylinder storage space may be required to maintain this temperature range.

System Operating Pressure

The normal system operating pressure for Kidde GX20 equipment is 25 bar at 21 °C.

**Table 3.4 Fill Range - GX20 Cylinder/Valve Assemblies
for Vertical Installation Only**

Part No.	Valve	Nominal Volume (litre)	LLI	Fill Range (kg)	Empty Weight (kg) (excluding safety cap)
E7763-101-01-EU	GCV40	5	No	3.0 to 4.5	11
E7763-102-01-EU	GCV40	8	No	4.0 to 9.0	14
E7763-103-01-EU	GCV40	16	No	8.0 to 18.0	19
E7763-104-01-EU	GCV40	28	No	14.0 to 31.5	26
E7763-105-01-EU	GCV40	51	No	24.5 to 56.5	44
E7763-106-05-EU	GCV50	81	No	39.0 to 90.5	65
E7763-107-02-EU	GCV50	81	Yes	39.0 to 90.5	66
E7763-108-01-EU	GCV50	142	No	68.0 to 158.5	106
E7763-109-01-EU	GCV50	142	Yes	68.0 to 158.5	107
E7763-110-01	GCV65	243	No	117.0 to 272.0	152
E7763-111-01	GCV65	243	Yes	117.0 to 272.0	153
E7763-110-05-EU	GCV80	243	No	117.0 to 272.0	202
E7763-111-05-EU	GCV80	243	Yes	117.0 to 272.0	203
E7763-112-01-EU	GCV80	368	No	177.0 to 408.0	245
E7763-113-01-EU	GCV80	368	Yes	177.0 to 408.0	246

3.9 DETERMINE OTHER REQUIRED COMPONENTS.

Container mounting brackets.

Detection and control equipment required.

Options such as reserve agent supply, pressure switches, etc.

3.10 PREPARE LAYOUT DRAWING OF HAZARD AND SUPPRESSION SYSTEM.

Determine pipe size and layout:

Locate cylinders based on the following:

1. Number of cylinders required.
2. Storage temperature and environmental conditions, i.e. weather, area classification, corrosive environment.
3. Accessibility.
4. Floor loading.

Locate piping based on the following:

1. Nozzle location.
2. Structural members for bracing pipe.

Draw piping isometric:

1. Dimension all pipe sections.
2. Locate all fittings.
3. Note all elevation changes.

Duration of discharge

Per NFPA 2001, the liquid agent discharge shall be completed in a nominal 10 seconds or less. Discharge times shorter than 10 seconds are desirable to minimise production of breakdown products. Discharge time as short as six seconds should be considered when circumstances permit.

The maximum discharge time for a Kidde GX20 system to reach the extinguishing concentration is 10 seconds or as otherwise required by the Authority Having Jurisdiction, but not less than six seconds.

3.11 LOCATE NOZZLES BASED ON THE FOLLOWING:

All nozzles must be installed in a vertical (pendant) position with the nozzle facing down.

Nozzles

Nozzles are available in both 180° and 360° discharge patterns. The 180° (sidewall) nozzle is designed for installation along the walls of the hazard, with the discharge directed away from the wall on which it is installed. The 360° nozzle is designed to be installed in the centre of the area being protected.

Ceiling Clearance

Nozzles must be installed so that the orifices are located 0.15 ± 0.05 m (6 ± 2 inches) below the ceiling.

Maximum Ceiling Height

The maximum ceiling height when using GX20 nozzles (both 180° and 360°) is 4.87 metres (16 feet). For hazard volumes higher than 4.87 metres, an additional row of nozzles is required. The 4.87m coverage height includes the 0.15 ± 0.05 m (6 ± 2 inches) nozzle distance below the ceiling.

Minimum Ceiling Height

The minimum ceiling height for a UL listed/FM Approved system is 0.3m (1ft).

Systems designed for enclosures 0.15 to 0.3 are acceptable, but not UL Listed or FM Approved.

Nozzle Area Coverage

Both the 180° and 360° nozzles were tested for maximum area coverage using a 12.2 wide by 13.4 metre long (40 by 44 feet) enclosure. Based on these parameters, the maximum area coverage for each nozzle is described as a straight-line distance from the nozzle to the farthest corner of the protected space. See Figure 3.1.

180° Nozzles

180° nozzles must be located 0.3 ± 0.05 m from a wall, with the orifices directed away from the wall. The nozzle shall be located as close to the centre of the wall as possible, but at least 1/3 of the way along the wall.

180° nozzles have a maximum coverage area defined as any rectangle that can be inscribed in a semicircle of distance 14.73m (48.3 ft, diagonal of a rectangle 12 x 13.3 m) Refer to figure 3.1 for further information.

180° nozzles may be used in a back-to-back configuration. The nozzles should be placed 0.3 m to 0.6 m (1 to 2 ft) apart.

360° Nozzles

360° Nozzles must be located as close to the centre of the enclosure as possible. 360° Nozzles have a maximum area defined as any rectangle that can be inscribed in a circle of radius 9.06 m (29.7 ft, diagonal of a rectangle 6 x 6.65 m) Refer to figure 3.1 for further information.

Multiple Nozzles

Nozzles whose discharge patterns will intersect must be placed at least 3.3m (10 ft) apart to assure adequate agent distribution.

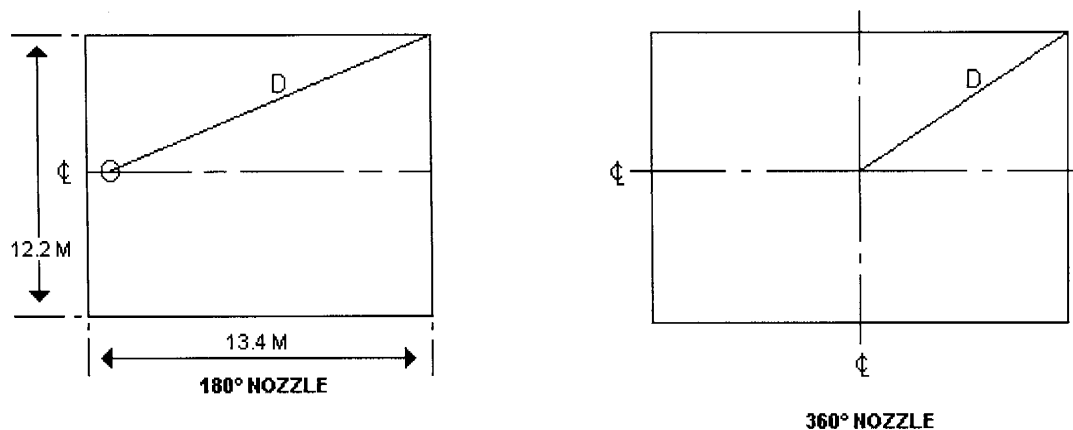

Figure 3.1 Nozzle Coverage

The maximum distances, D, are shown in Table 3.6

Table 3.6 Maximum Nozzle Straight Line Distances

Nozzle	D (metres)	D (feet)
180°	14.73	48.33
360°	9.06	29.73

Walls and Obstructions

FM-200 discharged from the nozzle requires a certain length from the nozzle to atomise into a gas. If the FM-200 comes into contact with a surface before the agent is fully atomised, frosting can occur. As a result, the concentration throughout the enclosure will be less than the required to appropriately protect the space. Therefore, nozzles must be located at least 1.2 to 1.8 m (4 to 6 ft) clearance from walls and/or significant obstructions (e.g. high rise racking and columns). If this requirement cannot be met, additional agent may be discharged to compensate for this agent “loss”.

Reduced Area Coverage

Consideration should be given to reducing nozzle spacing when obstructions that would impede the uniform distribution of FM-200 throughout the area are present. Nozzle coverage must be reduced to 7.6 x 7.6 m (25 x 25 ft) for enclosure heights of 0.15 to 0.3 m (6 to 12 inches).

Minimum average nozzle pressure

The nozzle pressure must be a minimum of 5.1 barg (74 psig) for the nozzle to effectively disperse the agent and mix the agent with the air of the enclosure being protected.

Examples Determine the maximum nozzle area coverage for 180° and 360° nozzles protecting a 6.1 metre wide enclosure.

180° Nozzle

Use D max. = 14.73 m (from Table 3.6)

Determine maximum length (L) of nozzle coverage.

$$L^2 = (14.73)^2 - (3.05)^2$$

$$L = (216.97 - 9.31)^{1/2} = 14.42 \text{ m maximum}$$

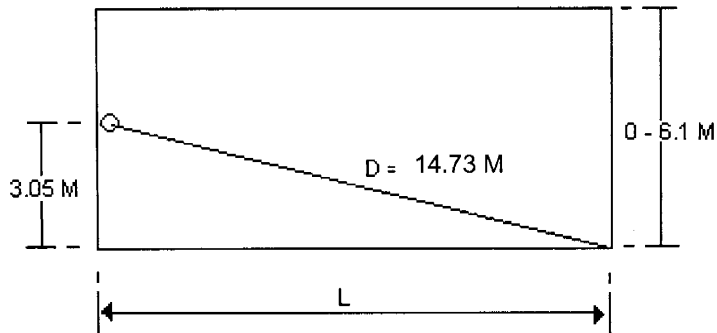

Figure 3.2 180° Nozzle Example

360° Nozzle

Use D max. = 9.1 m (from Table 3.6)

Determine maximum length (L) of nozzle coverage.

$$(L/2)^2 = (9.06)^2 - (3.05)^2$$

$$L = 2(82.08 - 9.31)^{1/2} = 17.06 \text{ m maximum}$$

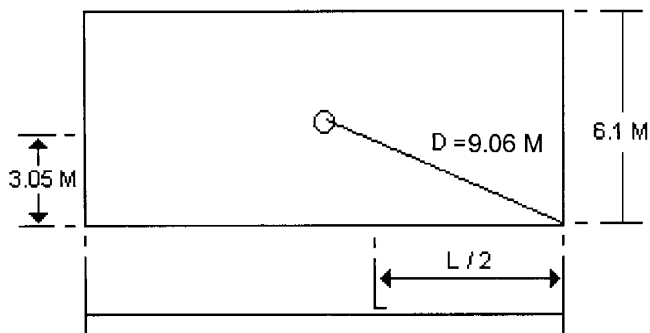

Figure 3.3 360° Nozzle Example

3.12 PIPE SIZE

Refer to Table 3.7 for an estimating guide for sizing distribution piping.

Table 3.7 Pipe Size Estimation

Nominal Pipe Size (mm)	Nominal Design Flow Rate (kg/sec)	
	Minimum	Maximum
15	0.5	1.4
20	0.9	2.5
25	1.6	3.9
32	2.7	5.7
40	4.1	9.0
50	6.4	13.6
65	9.0	25.0
80	13.6	40.9
100	25.0	56.8
125	40.9	90.9
150	54.5	136.4

NOTE: Table 3.7 is intended for use as a guide only. The Kidde Clean Agent Flow Calculation program must be used for the final design.

CAUTION

The GX20 Computer Design Software is the only calculation method to be used with GX20 FM-200 equipment. No other calculation method is acceptable.

The following sections describe the essential design parameters and design limitations which must be considered.

3.13 SOFTWARE LIMITS

First Branch Flow Split

To assure accuracy of the flow calculation, there are various agent flow limits. The maximum % agent in pipe for all systems is 80%. There is a limit on the allowable percentage of agent prior to the first tee. When these conditions are not met, the computer programme displays a warning. It is then up to the system designer to correct the piping volume up to the first branch split. For example, when reading Figure 3.4, in order to achieve 60% agent in pipe, a minimum of 8.3% agent is required before the first tee. When this condition is not met, the computer programme displays a warning. It is then up to the system designer to correct the piping volume to the first branch split to meet this design requirement. See Figure 3.4

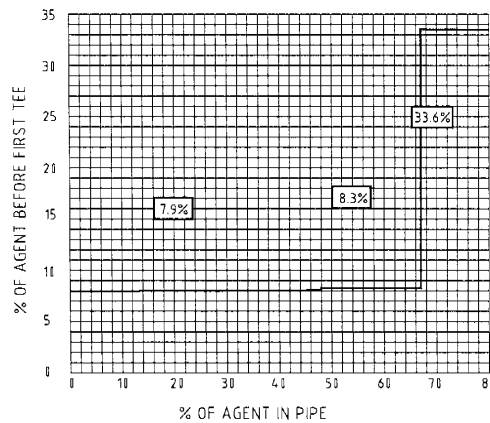

Figure 3-4 % of FM-200 In Pipe And Before First Tee

Maximum orifice area to pipe area ratio

The ratio between the nozzle orifice area for a 360° nozzle at the given node and the pipe cross sectional area for the pipe segment preceding that nozzle is 0.72, or 72%.

The ratio between the nozzle orifice area for a 180° nozzle at the given node and the pipe cross sectional area for the pipe segment preceding that nozzle is 0.66, or 66%.

Minimum orifice area to pipe area ratio

The ratio between the nozzle orifice area for a 360° nozzle at the given node and the pipe cross sectional area for the pipe segment preceding that nozzle is 0.27, or 27%.

The ratio between the nozzle orifice area for a 180° nozzle at the given node and the pipe cross sectional area for the pipe segment preceding that nozzle is 0.27, or 27%.

Maximum arrival time imbalance

The difference between liquid arrival times at any two of the nozzles must not exceed 0.8 seconds.

Maximum runout time imbalance

The difference between nozzle liquid runout times at any two of the nozzles must not exceed the 2.0 second maximum.

Maximum Elevation Differences in Pipe Runs

- If nozzles are only located above the container outlet, then the maximum elevation difference between the container outlet and the furthest horizontal pipe run or discharge nozzle (whichever is highest) shall not exceed 9m (30 ft).
- If nozzles are only located below the container outlet, then the maximum elevation difference between the container outlet and the furthest horizontal pipe run or discharge nozzle (whichever is lowest) shall not exceed 9m (30 ft).
- If nozzles are located both above and below the container outlet, then the maximum elevation difference between the furthest horizontal pipe runs or discharge nozzles (whichever is furthest) shall not exceed 9m (30 ft).

Note: If you have a system design that violates these limits, then you must consult Kidde fire Protection to determine what course of action should be taken.

3.14 TEE FLOW SPLITS

Flow splits at tee junctions are sensitive to gravity. Even though turbulent flow exists, there is a tendency for the vapour phase to migrate to the upper portion of the pipe leaving a more dense medium at the bottom of the pipe. For this reason, the following limitations must be observed and see Figure 3.5

1. Bull head tees must have both outlets in the horizontal plane. The inlet to a bull head tee may approach in a horizontal, vertically up or vertically down direction.
2. Side tees must have the inlet and both outlets all in the horizontal plane.
3. Elbows before tee splits going to separate hazards must be located a minimum distance of 15 pipe diameters (nominal) before the tee splits.
4. Tee splits going to separate hazards from a common supply line must be spaced a minimum of 15 pipe diameters (nominal) apart.
5. Pipe reducers before tee splits must be located a minimum of 15 pipe diameters (nominal) before the tee splits. Pipe reducers must be of the concentric reducer type.
6. Minimum flow out of a side tee branch is 10% of total flow at the tee.
7. For flow splits less than 30%, the split shall be done through a side tee with the smaller flow going through the side tee member. The minimum flow through the side tee member is 10%. The maximum flow through the tee is 90%.
8. For flow splits equal to or greater than 30%, the split shall be done through a bull head tee. The maximum flow split through a bull head tee is 70%.

Table 3.75 15 Pipe diameters

Pipe Size	15 Pipe diameters / m
15	0.192
20	0.287
25	0.381
32	0.475
40	0.573
50	0.762
65	0.954
80	1.143
100	1.524

NOTE : Where there is a change in elevation or another tee following a tee, the length of section between the tee and the change in elevation/second tee must be a **MINIMUM** of fifteen (15) times the nominal pipe diameter of the section.

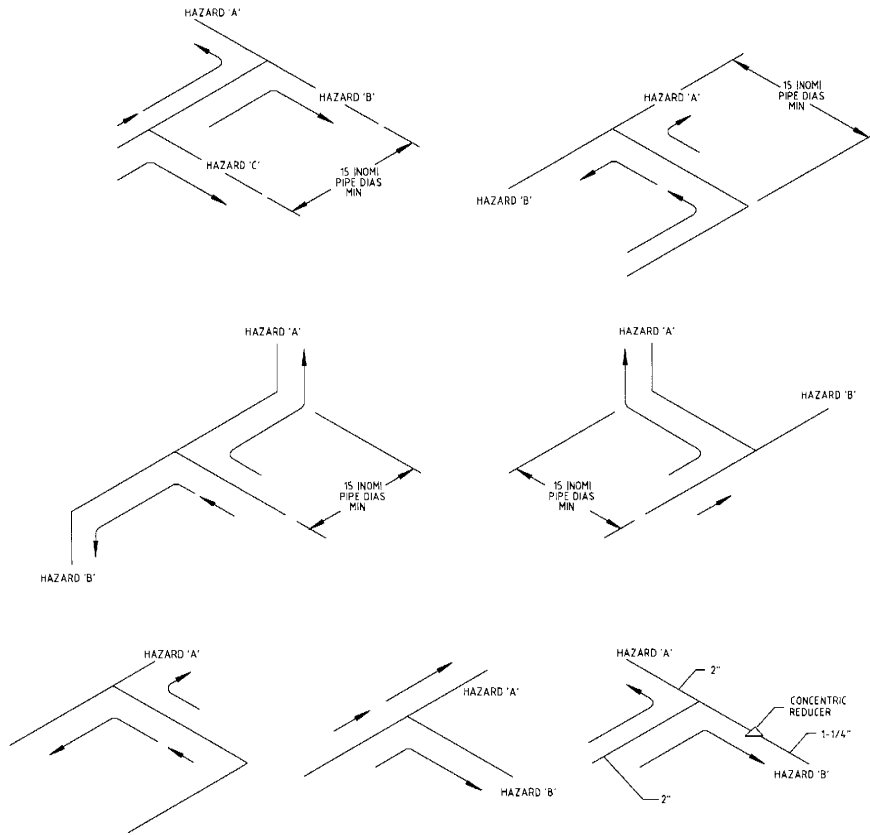

Figure 3-5 Acceptable Tee Flows Splits

3.15 CORNER PULLEY AND CABLE LIMITATIONS.

Refer to Table 3.8 for the maximum number of corner pulleys and cable length limitations:

Table 3.8 Corner Pulley and Cable Limitations

Control Head Type	Part No.	Watertight Pulley	Industrial Pulley	Max Cable Length (m)
Cable Operated	B6793-704	15	30	30.5
Electric/Cable	B6793-702	6	30	30.5
Electric/Cable XP	B6793-703	6	30	30.5

3.16 PRESSURE TRIP LIMITATIONS.

A pressure operated trip is used to close off the hazard space upon system discharge. The trips, operated by the system pressure are designed to release self-closing units for doors, windows and dampers. The maximum load to be attached to a pressure trip is 45 kg (100 lb), this is based on a minimum pressure of 6 bar (75 PSIG) at the pressure trip.

3.17 PRESSURE ACTUATION LIMITATIONS.

Four modes of pressure actuation cylinders are available for use.

3.17.1 For cylinders close coupled using pressure from (1) master GX20 cylinder

See Figure 3.6

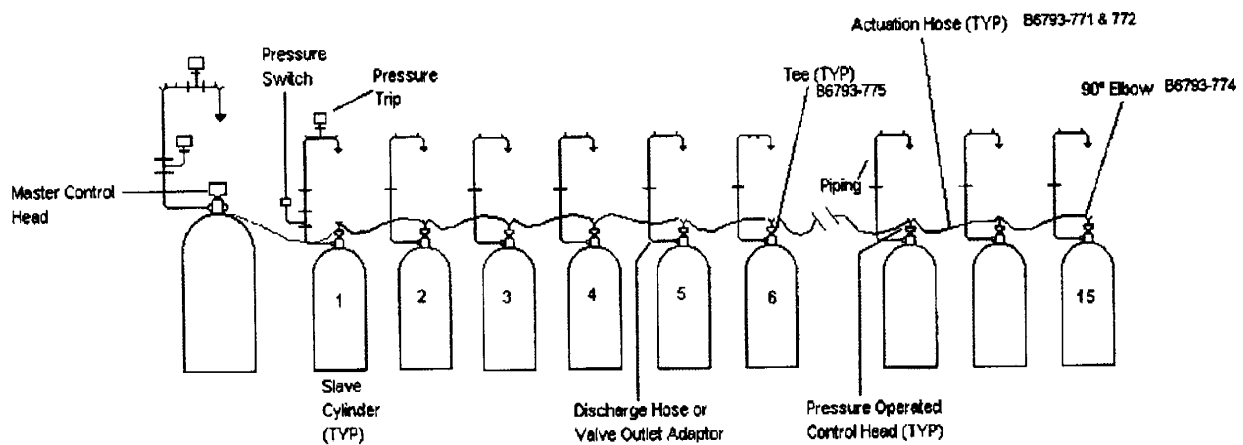

Figure 3.6 Pressure Actuation Using Pressure From (1) Master GX20 Cylinder to Actuate A Maximum of (15) GX20 Cylinders Close Coupled

One (1) master cylinder can actuate a maximum of fifteen (15) slave cylinders close coupled, using pressure operated control heads on the slave cylinders. The slave cylinder operation will be through pilot flexible hoses.

3.17.2 For cylinders NOT close coupled using pressure from (1) master GX20 cylinder

See Figure 3.7

One (1) master cylinder can pneumatically actuate a maximum of four (4) slave cylinders (maximum five cylinders in a group) "not close coupled" using pressure operated control heads on the slave cylinders. The slave cylinder operation will be through a 5/16 inch O.D. by 0.032 inch wall copper tubing actuator line having a maximum total length of 30.5 m (100 feet).

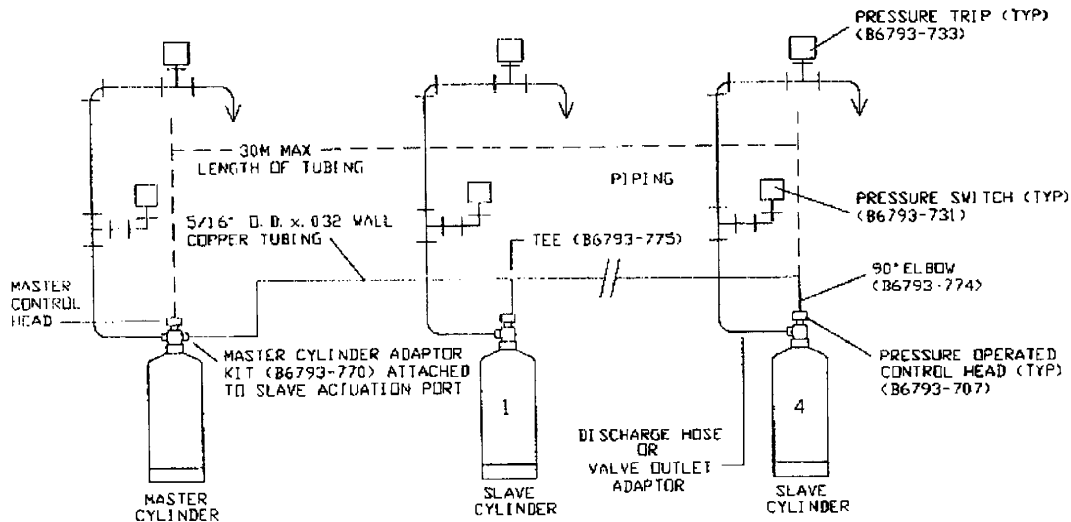

Figure 3.7 Pressure Actuation Using Pressure From (1) Master GX20 Cylinder (5 Cylinders Maximum NOT Close Coupled)

3.17.3 For cylinders NOT close coupled using nitrogen pressure from a nitrogen pilot cylinder.

See Figure 3.8

One (1) nitrogen pilot cylinder can pneumatically actuate from one to 15 slave GX20 cylinders using pressure operated control heads on the slave cylinders.

Slave operation will be through a 5/16 inch O.D. x 0.032 inch wall stainless steel tubing actuator line having the following limitations:

1. Maximum total length of tubing is 97.5 m (320 feet).
2. Maximum length of tubing between cylinder no. 1 and the last cylinder is 67 m (220 feet).
3. The nominal min/max length of tubing between the nitrogen pilot cylinder and GX20 cylinder number 1 is 0 to 30.5 m (0 to 100 feet).
4. If required, the nitrogen pilot cylinder can be located at a distance greater than 30.5 m (100 feet) from GX20 cylinder no. 1. In this instance, tubing length can be taken from the line between the slave cylinders and added to the line between the nitrogen cylinder and slave cylinder number 1, provided that the maximum total length of tubing does not exceed 97.5 m (320 feet).
5. The tubing actuation line must be designed for a minimum working pressure of 124 bar (1800 PSIG).

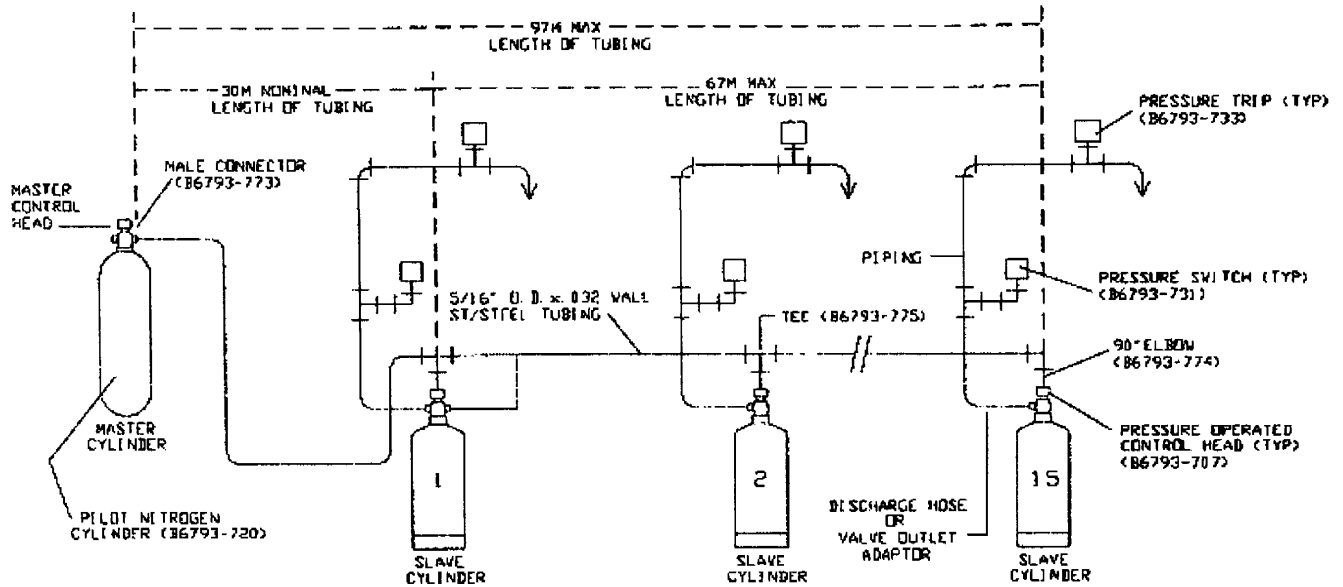

Figure 3.8 Pressure Actuation Using Pressure From (1) Nitrogen Pilot Cylinder To Actuate Maximum Of (15) GX20 Cylinders NOT Close Coupled

3.17.4 For cylinders close coupled using nitrogen pressure from (1) nitrogen pilot cylinder.

See Figure 3.9

One (1) nitrogen pilot cylinder can actuate from one to 15 slave GX20 cylinders using pressure operated control heads on the slave cylinders.

Slave operation will be through a 1/4 inch schedule 40 steel pipe actuator line having the following limitations:

1. Maximum length between nitrogen cylinder and the first GX20 cylinder is 97.5 m (320 feet).
2. Maximum quantity of flexible actuation hoses is 15. One at nitrogen cylinder, one at each GX20 cylinder.
3. All GX20 cylinders must be located adjacent to one another.

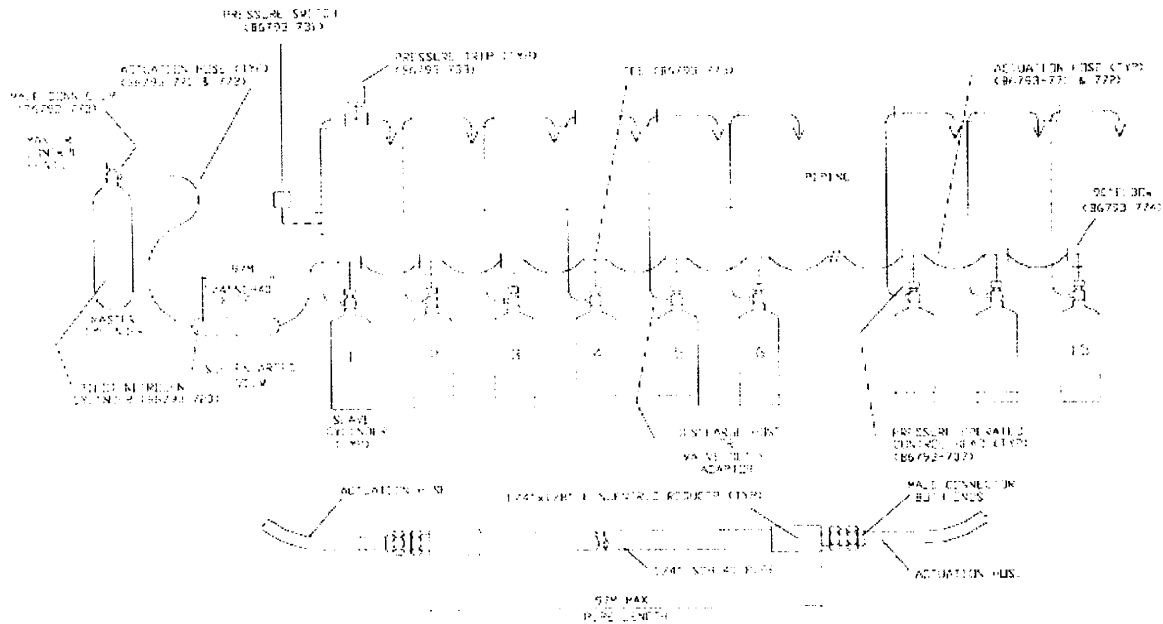

Figure 3.9 Pressure Actuation Using Pressure From (1) Nitrogen Pilot Cylinder To Actuate Maximum of (15) Close Coupled GX20 Cylinders

3.17.5 Use of multiple nitrogen pilot cylinders

See Figure 3.10.

Two or more remotely located nitrogen pilot cylinders can be used to actuate the GX20 systems described in Figures 3.8 and 3.9, provided that:

1. 1/4 inch check valves (Part No. B6793-786) shall be installed at the intersection of each pilot line to the main actuator line, see Figure 3.10
2. The total length of actuator line, from each nitrogen pilot cylinder to the GX20 cylinders, shall not exceed the limitation established.

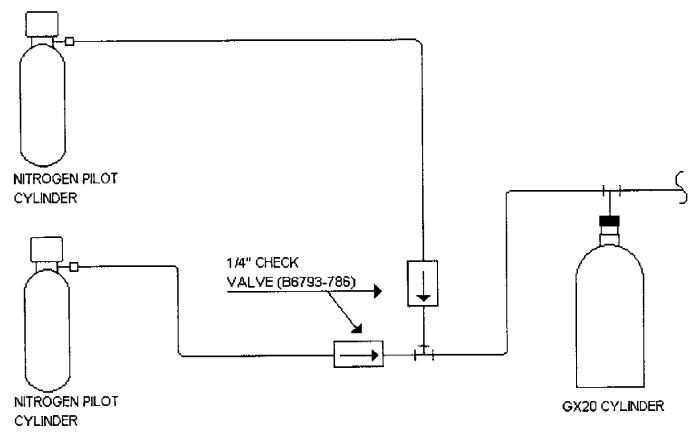

Figure 3.10 Multiple Nitrogen Pilot Cylinders

CHAPTER 4

INSTALLATION

4.1 GENERAL

This Chapter provides installation instructions covering components described in Chapter 2. Before installing, refer to the bill of material on the system layout drawing to ensure all required system components are available.

NOTE: Kidde systems are custom designed to serve a particular application. Kidde urges any prospective user of Kidde system or system components to be sure the system has been properly designed and installed per applicable standards and this manual. If used or surplus components are reassembled with components from another manufacturer into a revised system, the revised system may not function properly. Kidde accepts no responsibility for the operation of such systems. If Kidde components are assembled with components from another manufacturer without the express permission of Kidde, then Kidde accepts no responsibility for the operation of such systems. All system and component approvals would be void by any modifications.

All Kidde GX20 equipment must be installed to facilitate proper inspection, testing, manual operation, recharging and any other required maintenance as may be necessary. Equipment must not be subject to severe weather conditions or mechanical, chemical or other damage which could render the equipment inoperative. Equipment must be installed in accordance with NFPA Standard 2001, BS EN ISO 14520 (current editions), and the Authority Having Jurisdiction.

WARNING

GX20 CYLINDER/VALVE ASSEMBLIES MUST BE HANDLED, INSTALLED AND SERVICED IN ACCORDANCE WITH THE INSTRUCTIONS CONTAINED IN THIS CHAPTER.

FAILURE TO FOLLOW THESE INSTRUCTIONS CAN CAUSE GX20 CYLINDERS TO VIOLENTLY DISCHARGE, RESULTING IN SEVERE INJURY, DEATH AND OR PROPERTY DESTRUCTION.

4.2 DISTRIBUTION PIPING AND FITTINGS

4.2.1 Piping - General

Pipe and fittings must be installed in strict accordance with the system drawings and good commercial practices. The piping between the cylinder and the nozzles must be the shortest route possible, with a minimum of fittings. Any deviations in the routing or number of fittings must be approved by the design engineer prior to installation.

Examine the configuration to ensure the piping and nozzles do not interfere with objects in the hazard area. Also, confirm that the discharge pattern from the nozzles will not be obstructed by objects in the hazard area.

All piping shall be earth bonded and consideration given to the risk of electrostatic ignition during the discharge into a flammable atmosphere.

4.2.2 Pipe

All distribution piping must be in accordance with the latest requirements listed in NFPA 2001 and BS EN ISO 14520, and be of non-combustible material having physical and chemical characteristics, such that its integrity under stress can be predicted with reliability. Special corrosion resistant materials or coatings are required in severely corrosive atmospheres. The computer flow programme has only been verified for the specific types and schedule of pipe and fittings covered in this manual. There is a risk that the system may not supply the required quantity of agent in unbalanced systems when other pipe types and fittings are used.

Ferrous Piping: Black or galvanised steel pipe must be either ASTM A-53 seamless or electric resistance welded, Grade A or B, or ASTM A-53 furnace weld Class F (up to 1 ½" diameter) or ASTM A-106, Grade A, B, or C. ASTM A-120 and ordinary cast iron must not be used. The thickness of the pipe wall must be calculated in accordance with ANSI B-31.1, Power Piping Code. The internal pressure for this calculation shall not be less than the minimum piping design pressure 28 bar (402 psig) at 21°C (70°F). The minimum piping design pressure of 28 at 21°C corresponds to eighty percent of the maximum pressure of 35 bar (502 psig) in the agent container at the maximum storage temperature at 54°C (130°F), using the maximum allowable fill density at 1.121 kg/l (70 lb/cu.ft.).

4.2.3 Pipe Joining

The method of joining all pipe must be in accordance with the latest requirements listed in NFPA 2001. Acceptable fittings include screwed, flanges, welded, brazed flared, and compression. Rolled and grooved fittings must be approved for GX20 applications. Each fitting must be 300 lb. class. Ordinary cast iron fittings are not acceptable.

4.2.4 Reductions

Concentric bell reduces are the only means for reducing pipe size. Reducing bushings are not acceptable. Reductions can be made after a tee or union. Where reduces are used at tees, the reducers must be downstream of each tee. Reductions made after a union are possible only if the next change in direction (tee split) is located a minimum of 15 nominal pipe diameters

downstream or the concentric bell reducer.

4.2.5 Cleaning

All pipe lengths must be reamed, blown clear and swabbed with suitable solvents to remove burrs, mill varnish and cutting oil before assembly.

4.2.6 Threads

It is recommended that only Teflon tape be used and must be only applied to male pipe threads. Threads on all pipe and fittings must be tapered threads conforming to ANSI Specification B-20.1 or British Standard 21.

4.2.7 Installation

Pipe and fittings must be installed in strict accordance with the system drawings and good commercial practices. The piping between the cylinder and the nozzles must be the shortest route possible, with a minimum of fittings. Any deviations in the routing or number of fittings must be approved by the design engineer prior to installation.

Note: Strict piping rules regarding the flow splits to multiple hazards must be adhered to. Refer to paragraph 3.13 and 3.14 of this manual for proper tee instructions.

Piping must be reamed free of burrs and ridges after cutting, welding or threaded. All threaded joints must conform to ANI B1-20-1 or BS21, as appropriate. Joint compound or thread tape must be applied only to the male threads of the joint, excluding the first two threads. Welding must be in accordance with IX of the ASME Boiler and Pressure Vessel Code. Each pipe section must be swabbed clean, using a non-flammable organic solvent.

All piping must be blown clear with dry nitrogen or compressed air prior to installing the discharge nozzles.

The piping must be secured braced to account for discharge reaction forces and thermal expansion/contraction. Care must be taken to ensure the piping is not subjected to vibration and mechanical or chemical damage. All hangers must be UL listed and conform to general industry standards for pipe hangers.

4.2.8 Fittings

Fittings shall conform to the requirements of NFPA 2001, Sections 2-2.3 and A-2-2.3.1. Class 150 and cast iron fittings must not be used. Class 300lb malleable or ductile iron fittings in size 3-or British Standard 21.

NOTE: The flow calculation program allows for standard radius 90° elbows. Where square 90° or other types of elbows are used, an equivalent length addition or subtraction entry must be made to each relevant section on the calculation input.

4.3 DISCHARGE NOZZLES

After the system piping has been blown free of debris, install the discharge nozzles in strict accordance with the system drawings. Orientate the nozzles as shown on drawings. Make certain that the correct nozzle type(s), part number(s) and orifice size(s) are installed in the proper location(s).

4.4 PRESSURE ACTUATION LINES

The pressure actuation pipe must be 1/4 inch schedule 40 or 80 pipe. Copper and stainless steel tubing must be 5/16 O.D. x 0.032 inch wall. The pipe or tubing must be routed in the most direct manner with a minimum of fittings. Pipe and fittings must be in accordance with the requirements listed in Chapter 3. Tubing fittings can be flared or compression type. The pressure-temperature ratings of the fitting manufacturer must not be exceeded.

Piping and tubing must be reamed free of burrs and ridges after cutting, threading or flaring. Upon assembly, pipe and tubing must be blown out with dry nitrogen, carbon dioxide or compressed air. Actuation lines should be securely braced and isolated from vibration, mechanical or chemical damage.

Tubing should be enclosed in steel conduit when penetrating walls and in areas subject to mechanical damage.

4.5 VALVE OUTLET ADAPTOR

WARNING

ALWAYS CONNECT VALVE OUTLET ADAPTOR INTO SYSTEM PIPING (UNION CONNECTION) BEFORE CONNECTING TO GX20 CYLINDER.

Install valve outlet adaptor in system piping. Tighten securely.

4.6 FLEXIBLE DISCHARGE HOSE

WARNING

ALWAYS CONNECT FLEXIBLE DISCHARGE HOSE INTO SYSTEM PIPING BEFORE CONNECTING TO GX20 CYLINDER.

Attach flexible discharge hose from system piping to cylinder valve. Tighten securely. See Figure 4.1

Figure 4.1 Flexible Hose Directly Into System Piping

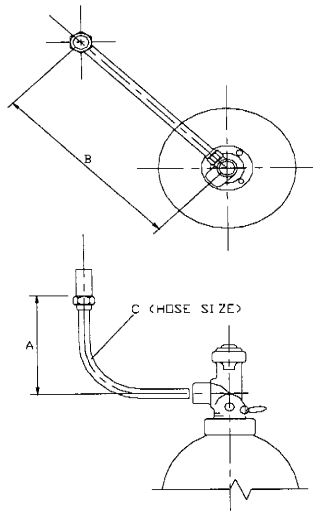

Table 4.1 Flexible hose dimensions

Cylinder Capacity (litre)	A (mm)	B (mm)	C GCV [mm] (inch)
5	372	426	GCV40 (1-1/2)
8	372	426	GCV40 (1-1/2)
16	372	426	GCV40 (1-1/2)
28	372	426	GCV40 (1-1/2)
51	372	426	GCV40 (1-1/2)
81	483	553	GCV50 (2)
142	483	553	GCV50 (2)
243	753	832	GCV65 (2-1/2)
243	838	914	GCV80 (3)
368	838	914	GCV80 (3)

NOTES: Dimensions A and B must be maintained in order to obtain a smooth radius in flexible loop. The hose may require an adaptor to connect to system piping.

4.7 MASTER CYLINDER ADAPTOR KIT

Part No. B6793-770.

See Figure 4.2

NOTE: Master cylinder adaptor installation can be accomplished safely with a pressurised cylinder.

1. Remove 1/4 inch pipe plug from slave actuation port on master cylinder valve.
2. Prior to assembling the adaptor (Item 2) to the cylinder valve, apply Teflon tape to male threads on adaptor.
3. Ensure cap (Item 1) is screwed onto adaptor outlet port before assembling to the cylinder valve.
4. Install adaptor into slave actuation port on master cylinder valve.
5. Attach label (Item 3) to valve body.

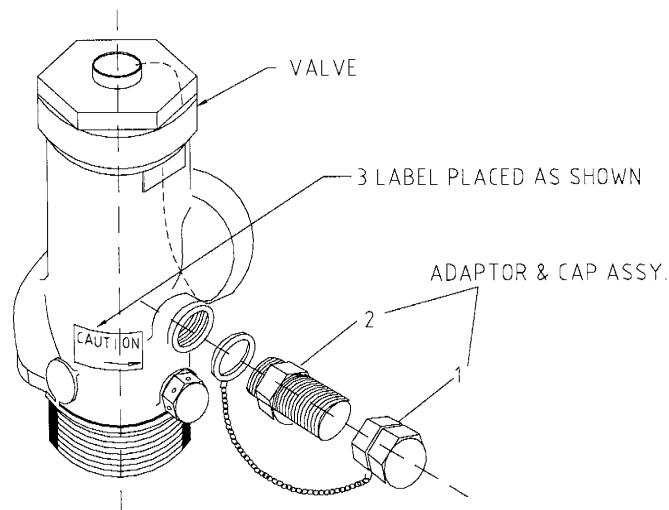

Figure 4.2 Master Cylinder Adaptor Kit

4.8 GX20 CYLINDER / VALVE ASSEMBLIES

The GX20 cylinders should be located as close to the protected hazard area as possible. The assemblies shall be located in a readily accessible location to allow for manual actuation and ease of inspection, service and maintenance. The installed cylinders shall be located in an environment protected from the weather and where the ambient temperature does not exceed 27 °C (80 °F) nor fall below 16 °C (60 °F). External heating or cooling may be required to maintain this temperature range. The following installation instructions must be followed in the exact sequence outlined below to prevent accidental discharge, bodily injury or property damage.

WARNING

CYLINDERS MUST BE LOCATED AND MOUNTED WHERE THEY WILL NOT BE SUBJECT TO ACCIDENTAL DAMAGE OR MOVEMENT. SUITABLE PROTECTION TO PREVENT ACCIDENTAL DAMAGE OR MOVEMENT MUST BE INSTALLED WHEN NECESSARY.

4.8.1 Single Cylinder Systems

1. Position GX20 cylinder in designated location and secure in place with cylinder strap and attaching hardware. Remove valve protection cap and retain for future shipping purposes. Orientate cylinder with valve outlet angled toward system piping.

WARNING

DISCHARGE HOSES OR VALVE OUTLET ADAPTORS MUST BE CONNECTED INTO SYSTEM PIPING (UNION CONNECTION) BEFORE ATTACHING TO CYLINDER VALVES.

IF A VALVE OUTLET ADAPTOR IS USED, A UNION MUST BE INSTALLED IN THE DISCHARGE PIPING.

2. Remove safety cap from cylinder valve outlet port.
3. Connect the appropriate flexible discharge hose or valve outlet adaptor to cylinder outlet port.

WARNING

CONTROL HEAD MUST BE IN THE SET POSITION BEFORE ATTACHING TO GX20 CYLINDERS IN ORDER TO PREVENT ACCIDENTAL DISCHARGE, I.E. ACTUATING PIN IS IN THE FULLY RETRACTED OR SET POSITION.

4. Remove protection cap from cylinder valve actuation port.
5. Install control head to cylinder valve actuation port.

4.8.2 Multiple Cylinder Systems; and Main and Reserve Systems

Close coupled, activated with (1) Master GX20 cylinder, see Figure 3.6

1. Position cylinders in designated location and secure in place with cylinder straps and attaching hardware. Orientate cylinders so that valve outlet is angled towards discharge piping.

WARNING

DISCHARGE HOSES OR VALVE OUTLET ADAPTORS MUST BE CONNECTED INTO SYSTEM PIPING (UNION CONNECTION) BEFORE ATTACHING TO CYLINDER VALVES

2. Remove safety cap from one cylinder outlet port and connect flexible discharge hose to cylinder outlet port. Repeat for each cylinder in system.

WARNING

CONTROL HEADS MUST BE IN THE SET POSITION BEFORE ATTACHING TO GX20 CYLINDERS IN ORDER TO PREVENT ACCIDENTAL DISCHARGE.

3. Remove protection caps from slave cylinder actuation ports.
4. Install pressure operated control heads to slave cylinder valve actuation ports.
5. Unscrew cap from slave port on installed master cylinder adaptor kit.
6. Connect flexible actuation hoses to tee installed on first slave cylinder assembly.
7. Connect flexible hoses to the actuation line and tees on all remaining slave cylinders.
8. Connect last actuation hose to elbow mounted on pressure operated control head installed on last slave cylinder.

WARNING

CONTROL HEAD MUST BE IN THE SET POSITION BEFORE ATTACHING TO GX20 CYLINDERS IN ORDER TO PREVENT ACCIDENTAL DISCHARGE.

9. Attach master control head to master cylinder.

4.8.3 Multiple Cylinder Systems

Not close coupled, activated with (1) Master GX20 cylinder, see Figure 3.7

1. Position cylinders in designated location and secure in place with cylinder straps and attaching hardware. Orientate cylinders so that valve outlet is angled towards discharge piping.

WARNING

DISCHARGE HOSES OR VALVE OUTLET ADAPTORS MUST BE CONNECTED INTO SYSTEM PIPING (UNION CONNECTION) BEFORE ATTACHING TO CYLINDER VALVES

2. Remove safety cap from one cylinder outlet port and connect flexible discharge hose to cylinder outlet port. Repeat for each cylinder in system.

WARNING

CONTROL HEADS MUST BE IN THE SET POSITION BEFORE ATTACHING TO GX20 CYLINDERS IN ORDER TO PREVENT ACCIDENTAL DISCHARGE.

3. Remove protection caps from slave cylinder actuation ports.
4. Install pressure operated control heads to slave cylinder valve actuation ports.
5. Unscrew cap from slave port on installed master cylinder adaptor kit.
6. Attach 5/16 inch tubing to master cylinder adaptor.
7. Connect 5/16 inch tubing to tee mounted on pressure operated control head installed on first slave cylinder.
8. When installed, connect all slave cylinders to first slave cylinder by connecting actuation tubing to tees and elbow mounted on pressure operated control heads.

WARNING

CONTROL HEAD MUST BE IN THE SET POSITION BEFORE ATTACHING TO GX20 CYLINDERS IN ORDER TO PREVENT ACCIDENTAL DISCHARGE.

9. Attach master control head to master cylinder.

4.8.4 Multiple Cylinder Systems

Not close coupled, actuated with nitrogen pilot cylinder, see Figure 3.8

1. Position cylinders in designated location and secure in place with cylinder straps and attaching hardware. Orientate cylinders so that valve outlet is angled towards discharge piping.

WARNING

DISCHARGE HOSES OR VALVE OUTLET ADAPTORS MUST BE CONNECTED INTO SYSTEM PIPING (UNION CONNECTION) BEFORE ATTACHING TO CYLINDER VALVES.

2. Remove safety cap from one cylinder outlet port and connect flexible discharge hose to cylinder outlet port. Repeat for each cylinder in system.

WARNING

CONTROL HEADS MUST BE IN THE SET POSITION BEFORE ATTACHING TO GX20 CYLINDERS IN ORDER TO PREVENT ACCIDENTAL DISCHARGE.

3. Remove protection caps from slave cylinder actuation ports.
4. Install pressure operated control heads to slave cylinder valve actuation ports.
5. Attach 5/16 inch tubing to tees and elbow mounted on pressure operated control heads.
6. Connect 5/16 inch tubing between the nitrogen pilot cylinder and the tee installed on the first slave cylinder assembly.

WARNING

DO NOT ATTACH MASTER CONTROL HEAD TO NITROGEN PILOT CYLINDER UNTIL ALL PRESSURE ACTUATOR LINE CONNECTIONS ARE COMPLETED.

4.8.5 Multiple Cylinder Systems

Close coupled, activated with nitrogen pilot cylinder, see Figure 3.9

1. Position cylinders in designated location and secure in place with cylinder straps and attaching hardware. Orientate cylinders so that valve outlet is angled towards discharge piping.

WARNING

DISCHARGE HOSES OR VALVE OUTLET ADAPTORS MUST BE CONNECTED INTO SYSTEM PIPING (UNION CONNECTION) BEFORE ATTACHING TO CYLINDER VALVES.

2. Remove safety cap from one cylinder outlet port and connect flexible discharge hose to cylinder outlet port. Repeat for each cylinder in system.

WARNING

CONTROL HEAD MUST BE IN THE SET POSITION BEFORE ATTACHING TO GX20 CYLINDERS IN ORDER TO PREVENT ACCIDENTAL DISCHARGE.

3. Remove protection caps from GX20 cylinder actuation ports.
4. Install pressure operated control heads to GX20 cylinder valve actuation ports.
5. Connect flexible actuation hoses to tee installed on first slave cylinder assembly.
6. Connect flexible hoses to the actuation line and tees on all remaining slave cylinders.
7. Connect last actuation hose to elbow mounted on pressure operated control head installed on last slave cylinder.
8. Connect flexible hoses, 5/16 inch tubing, between the nitrogen pilot cylinder and the tee installed on the first slave cylinder assembly.

WARNING

DO NOT ATTACH MASTER CONTROL HEAD TO NITROGEN PILOT CYLINDER UNTIL ALL PRESSURE ACTUATION LINE CONNECTIONS ARE COMPLETED.

4.9 CYLINDER STRAPS AND BRACKETS

WARNING

EACH CYLINDER STRAP OR BRACKET MUST BE SECURELY ANCHORED TO STRUCTURAL SUPPORTS TO ABSORB THE FORCE GENERATED BY CYLINDER DISCHARGE.

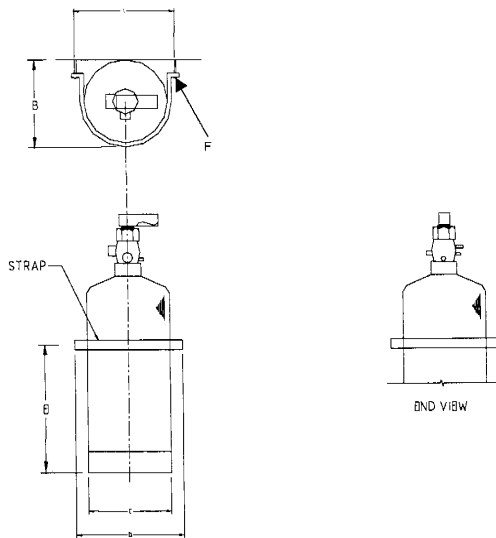
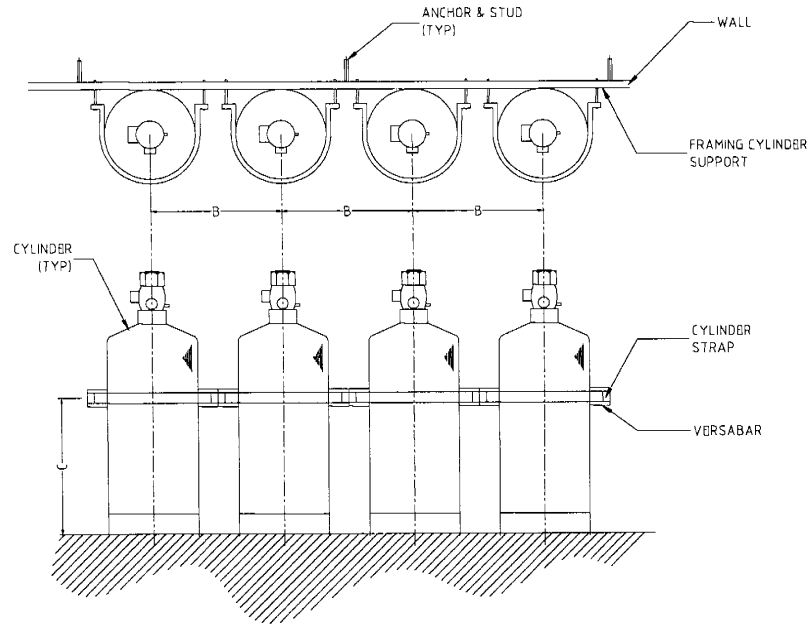

Figure 4.3 Typical GX20 Cylinder Installation - Vertical Mounting

NOTE: Dimension B does not include for any fixing channels. If a channel is used, then dimension B will increase from the wall by the depth of the channel.

Cylinder Capacity (litre)	Strap Part No.	Dimensions (nominal)					
		A (mm)	B (mm)	C (mm)	D (mm)	E (mm)	F (mm)
5	C6331-103	219	182	180	245	187	12
8	C6331-103	219	182	180	245	356	12
16	C6331-104	272	232	230	297	394	12
28	C6331-104	272	232	230	297	699	12
51	C6331-105-02	370	328	324	411	546	16
81	C6331-105-02	370	328	324	411	940	16
142	C6331-106	454	412	406	495	1118	16
243	C6331-107	613	566	560	654	953	16
368	C6331-121	661	616	610	705	1232	16

Install cylinder straps as shown in Figures 4.3



Cylinder Capacity (litre)	Dimensions (nominal)		Strap Part No.
	B (mm) *	C (mm)	
5	279	187	C6331-103
8	279	356	C6331-103
16	330	394	C6331-104
28	330	699	C6331-104
51	457	546	C6331-105-02
81	457	940	C6331-105-02
142	533	1118	C6331-106
243	686	953	C6331-107
368	762	1232	C6331-121

Figure 4.6 Cylinder Strap - Multiple Cylinders

Install brackets as shown in Figure 4.6

NOTE * See Figure 4.6, if GX20 cylinders are to be connected to a manifold, then they must be spaced between centres, as that of the manifold inlet ports. Refer to the data sheets in section 1 of this manual.

4.10 ELECTRIC CONTROL HEADS

4.10.1 ELECTRIC CONTROL HEADS FOR USE WITH GCV40, 50 AND 65 VALVES

Part Nos. B6793-709 and B6793-701.

See Figures 4.7 (B6793-709) and 4.8 (B6793-701).

WARNING

BEFORE INSTALLING CONTROL HEAD ON GX20 CYLINDER VALVE, ENSURE CONTROL HEAD IS IN SET POSITION (ACTUATING PIN IS IN THE FULLY RETRACTED OR SET POSITION). FAILURE TO POSITION CONTROL HEAD IN SET POSITION WILL RESULT IN ACCIDENTAL GX20 CYLINDER DISCHARGE WHEN CONTROL HEAD IS INSTALLED ON CYLINDER VALVE. PERSONAL INJURY OR PROPERTY DAMAGE COULD OCCUR.

WARNING

ELECTRIC CONTROL HEAD, PART NO. B6793-709, IS DESIGNED FOR INSTALLATION TO KIDDE GCV40, 50 AND 65 GX20 CYLINDER/ VALVES ONLY. INSTALLATION OF THIS CONTROL HEAD TO ANY OTHER DEVICE, E.G. PRESSURE OPERATED CONTROL HEAD, WILL RESULT IN FAILURE OF DEVICE TO OPERATE WHEN CONTROL HEAD IS ACTUATED.

1. Remove protection cap from GX20 cylinder actuation port. Ensure that control head is in SET position (actuating pin is in the fully retracted or SET position).
2. Install electric control head on cylinder actuation port. Tighten swivel nut.
3. Make electrical connections.

CAUTION

These actuators are polarised, improper wiring will result in failure of device to operate.

The stackable control head (P/N B6793-709) cannot be used with the GCV80 valve as it does not have sufficient force to activate this valve and may result in system failure. Use the electrical control head (P/N B6793-859) with the GCV80 valve.

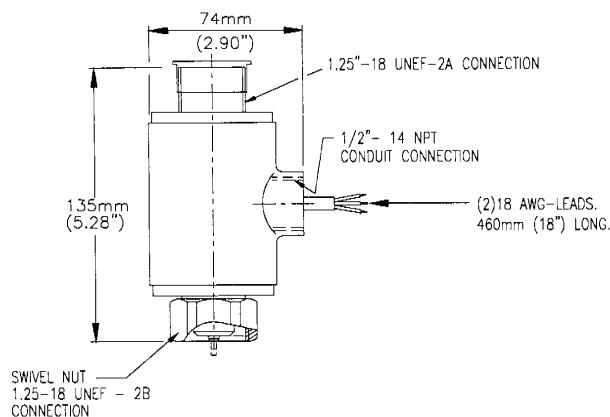
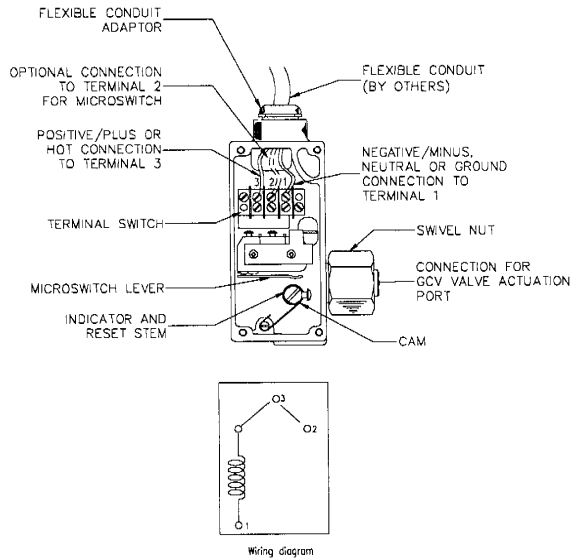

Figure 4.7 Electric Control Head, Stackable



4.8 Electric Control Head

4.10.2 ELECTRIC CONTROL HEAD FOR USE WITH GCV80

Part No. B6793-859

The Flameproof and Explosion Proof Control Head can be mounted directly on either the cylinder valve or the stop/directional valve. Care should be taken to ensure that the actuating pin is in the set position when attaching the control head to the cylinder or stop/directional valve to avoid accidental system discharge. Tighten the swivel nut securely in place.

When installing the Flameproof and Explosion Proof Control Head in hazardous locations, wiring connections must be terminated in explosion proof junction boxes.

The lead wires must be connected using the indicated polarity (red to positive, black to negative) in order to obtain correct operation.

Once the Flameproof and Explosion Proof Control Head has operated, it should be removed from the cylinder or the stop/directional valve and mechanically reset.

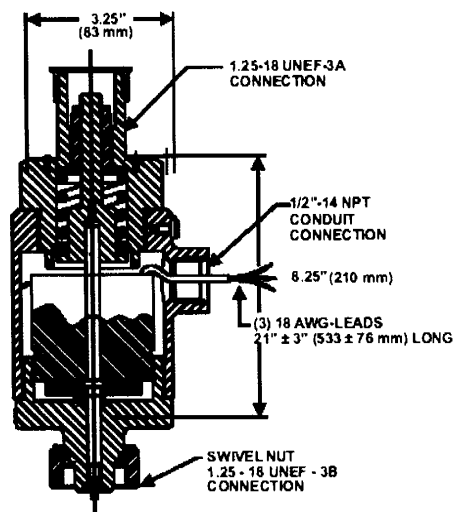

Figure 4.8.5 Electrical Control Head (suitable for use with GCV80)

4.11 PRESSURE OPERATED CONTROL HEADS

Part No. B6793-707

WARNING

ENSURE THAT PILOT LINE IS UNPRESSURISED AND ACTUATING PINS ARE IN THE RETRACTED (SET) POSITION. FAILURE TO FOLLOW THIS PROCEDURE WILL RESULT IN ACCIDENTAL DISCHARGE OF THE GX20 CYLINDER WHEN CONTROL HEAD IS INSTALLED ON CYLINDER VALVE.

1. Remove protection cap from GX20 cylinder actuation port.
2. Install pressure operated control head with flexible actuation hose or tubing attached to actuation line.

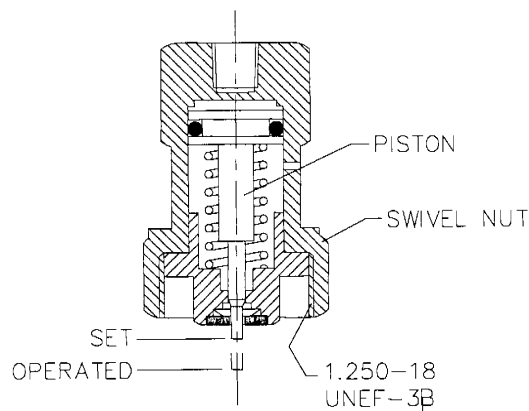

Figure 4.9
Pressure Operated Control Head

4.12 ELECTRIC AND CABLE OPERATED CONTROL HEAD

The following procedures are to be performed before attaching control head to cylinder valve, see Figure 4.10

1. Remove four screws holding cable housing cover on control head. Remove cover.
2. Position control head in the approximate installed position at the GX20 cylinder valve control port but do not assemble onto actuation port of GX20 cylinder valve.
3. Check that control head is in the SET position.
4. Assemble the pull cable conduit to the conduit connection on the control head.
5. Feed cable into control head through the hole in the operating lever.
6. Feed cable through the cable clamp. Pull cable taut, allowing approximately 10 to 15 mm clearance between the cable clamp and the operating lever. Tighten set screws in cable clamp to secure cable to clamp.
7. Cut off excess cable.
8. Verify manual remote cable operation to ensure control head actuates and all cable clamps are tight.
9. Pull cable back to its normal set (unoperated) position.
10. Reset control head.

11. Replace control head cover.
12. Examine seal wire at safety pull pin. Make sure it is intact.
13. Make all electrical connections.
14. Assemble control head to cylinder valve or stop valve actuation port. Tighten swivel nut securely.

NOTE: The corner pulley installation should allow flexibility for installation and removal of control head from GX20 cylinder.

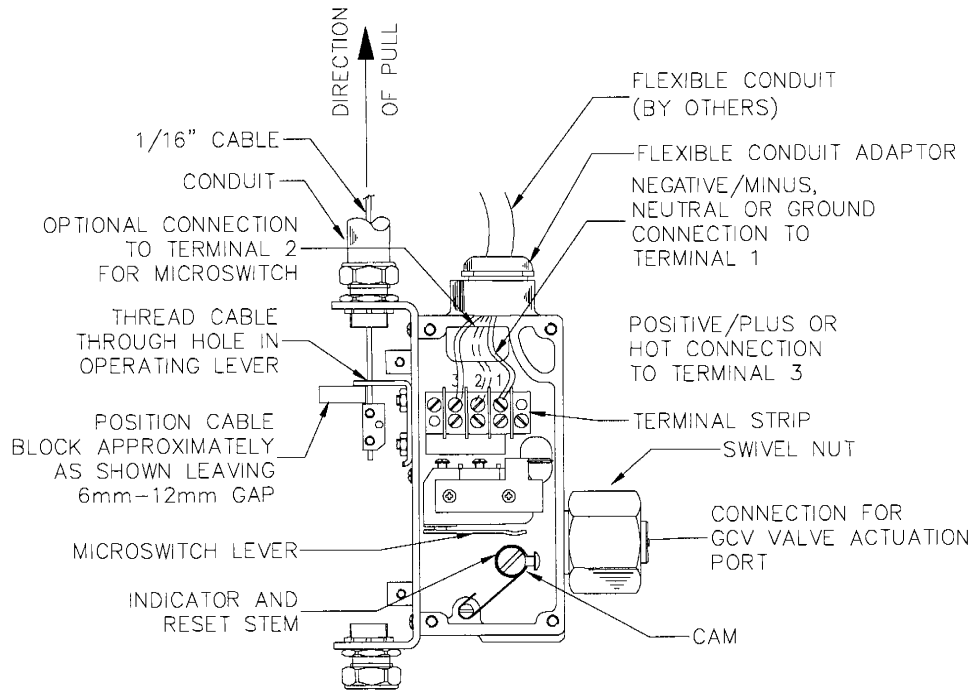

Figure 4.10 Electric Cable Operated Control Head

4.13 CABLE OPERATED CONTROL HEAD

Part No. B6793-704

WARNING

THE CABLE OPERATED CONTROL HEAD, PART NO. B6793-704, IS NOT TO BE USED IN CONJUNCTION WITH THE STACKABLE PRESSURE OPERATED CONTROL HEAD, PART NO. B6793-708. INSTALLATION OF THE CABLE OPERATED CONTROL HEAD ONTO THE ACTUATION PORT OF THE STACKABLE PRESSURE OPERATED CONTROL HEAD WILL RESULT IN FAILURE OF THE DEVICES TO OPERATE CORRECTLY.

The following procedures are to be performed before attaching control head to cylinder valve.

1. Remove protection cap from cylinder actuation port.
2. Remove cover from control head and take out wheel assembly, cable pipe locknut and closure disc.

3. Make sure plunger is below surface of control head body. Position control head at valve control port with arrow pointing in direction of pull.
4. Assemble cable pipe locknut to cable pipe and place cable pipe in position in control head body.
5. Slide wheel assembly on control cable to proper SET position. Tighten set screws securely. Make sure wheel assembly is at start of stroke.
6. Cut off excess control cable close to wheel assembly.
7. Insert closure disc and replace cover on control head. Control head is now armed!

CAUTION

To ensure that manual lever does not snag or trap cable, make sure local manual release lever is in SET position with locking pin and seal wire installed before assembling control head cover to body.

8. Assemble control head to cylinder valve or stop valve actuation port. Tighten swivel nut securely.

4.14 LEVER OPERATED CONTROL HEAD

Part No. B6793-705

1. Ensure control head is in the SET position with safety pull pin and seal wire intact.
2. Remove protection cap from cylinder or stop valve actuation port.
3. Assemble control head to cylinder valve and tighten swivel nut securely.

4.15 NITROGEN CYLINDER AND MOUNTING BRACKET

Part Nos. B6793-720 and B6793-721

1. Locate nitrogen cylinder mounting bracket in area where cylinder valve assembly and control head will be protected from inclement weather by a suitable total or partial enclosure, preferably adjacent to GX20 cylinders.
2. Install mounting bracket clamps and hardware. Install nitrogen cylinder in position in mounting bracket, tighten sufficiently to hold cylinder in place while allowing cylinder enough free play to be manually rotated.
3. Remove nitrogen cylinder valve protection cap.
4. Manually rotate cylinder until cylinder valve discharge outlet is in desired position.

CAUTION

Nitrogen cylinder must be positioned so that control head, when installed, is readily accessible and cannot be obstructed during manual operation.

5. Securely tighten mounting bracket clamps and hardware.
6. Attach adaptor (Part No. B6793-773) and connect nitrogen pilot lines.
7. Remove protective cap from cylinder valve actuation port.

WARNING

ENSURE CONTROL HEAD IS IN THE SET POSITION BEFORE ATTACHING TO CYLINDER VALVE. FAILURE OF CONTROL HEAD TO BE IN SET POSITION WILL RESULT IN ACCIDENTAL GX20 SYSTEM DISCHARGE.

8. Install control head to cylinder valve actuation port; tightening securely.

4.16 DISCHARGE PRESSURE SWITCH

Part Nos. B6793-731 and B6793-732

WARNING

TO PREVENT PERSONNEL INJURY, DE-ENERGISE ALL ELECTRICAL COMPONENTS PRIOR TO PRESSURE SWITCH INSTALLATION.

Pressure switches must be connected to the piping in an upright position as shown on the system drawings. Both the standard and explosion-proof switches have 1/2 inch NPT pressure inlets to connect to the system piping. The electrical connections are either 1/2 inch conduit knockouts for the standard pressure switch and 1 inch NPT fittings for the explosion proof pressure switch.

4.17 PRESSURE TRIP

Part No. B6793-733

Install the pressure trip on the piping in the horizontal position as shown on the system drawings. Connect the trip to the piping with 1/2 inch schedule 40 pipe. The minimum operating pressure required is 6 bar (75 PSIG). The maximum allowable load to be attached to the retaining ring is 45 kg (100 lb).

4.18 MANUAL PULL STATION

Part No. B6793-782

1. Locate the remote pull boxes as shown on the system installation drawings.
2. Connect pull boxes to the control heads using 3/8 inch schedule 40 pipe. Do not run more than one cable in each pipe run.
3. Install a corner pulley at each change in pipe direction. Do not bend the pipe.
4. Beginning at the pull boxes, remove the covers of the first corner pulley. Feed the cable through the pulley into the 3/8 inch pipe. Connect one end of the cable to the cable fastener in the pull box, allowing short end to project at least 13 mm. Seat cable in groove by pulling on long end. Screw fastener and cable into handle. Route the other end to the control heads, taking up as much slack as possible. Attach the end of the cable to the fastener in the control head.
5. Reattach the corner pulley covers.
6. Check that control head is in SET position. Install the control head to the GX20 cylinder or nitrogen pilot cylinder.

4.19 SUPERVISORY PRESSURE SWITCHES

Part Nos. 06-118262-001 and B6793-908

Installation of the supervisory pressure switch can be accomplished safely on a pressurised cylinder.

WARNING

PRIOR TO PRESSURE SWITCH INSTALLATION, DE-ENERGIZE ALL ELECTRICAL COMPONENTS TO PREVENT PERSONNEL INJURY.

CAUTION

WHEN ATTACHING OR REMOVING THE SUPERVISORY PRESSURE SWITCH FROM THE CYLINDER VALVE, ATTACH A WRENCH TO FITTING A AND HOLD SECURELY WHILE TIGHTENING OR LOOSENING THE PRESSURE SWITCH.

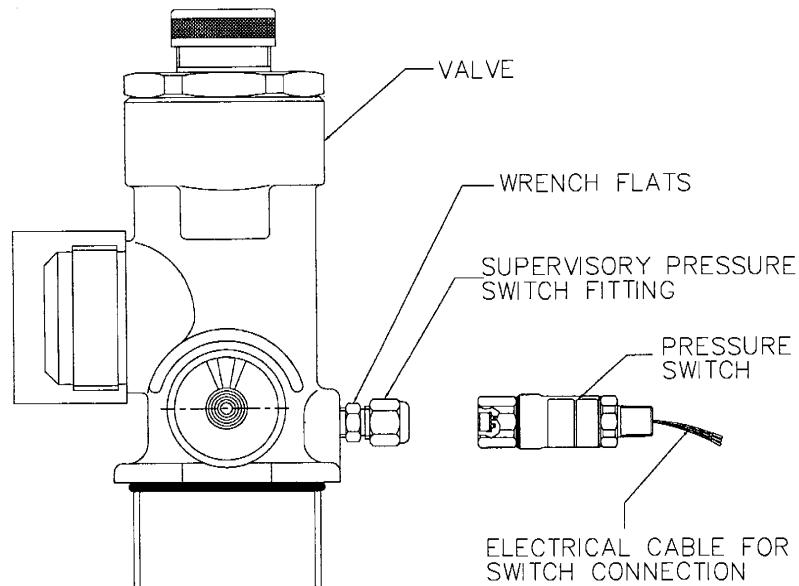

Figure 4.11. Installation of Supervisory Pressure Switch (Up to GCV65 Valve)

The control panel must be UL Listed and/or FM Approved for releasing device service and compatible with Kidde FM-200 equipment.

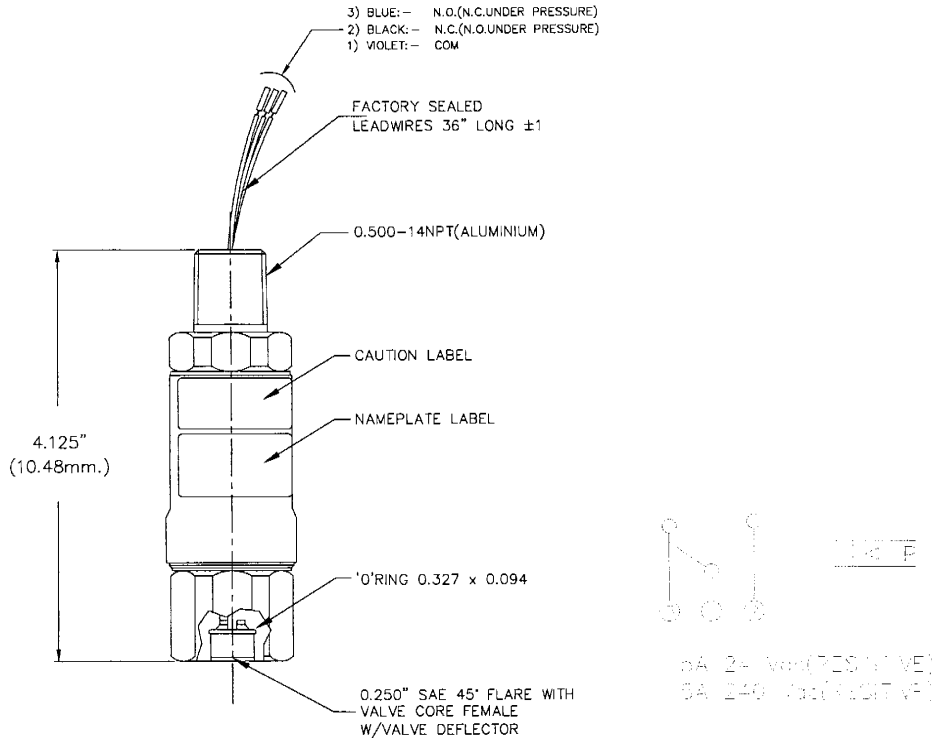

Figure 4.12. Supervisory Pressure Switch Electrical connections

Note: When cylinder supervisory pressure switch (Part Nos. 06-118262-001 and B6793-908) is connected to a supervised control panel circuit, and the switch is wired NC under pressure, it is not possible to distinguish between a wiring fault and a loss of container pressure. This configuration should only be used if accepted by the Authority Having Jurisdiction.

4.19.1 INSTALLATION PRESSURE SWITCH 06-118262-001

Install the pressure switch as follows:

Note: Do not use with GCV80 valve.

1. Check the sealing surface of the flare connection of the supervisory switch is not scratched, dented or scored etc.
2. Remove the end cap from the pressure switch port of the valve. This is a flare fitting and does not require tape or any other type of sealant.
3. Install the pressure switch onto the pressure port of the valve. Be sure to secure the pressure port with a spanner so that you are not turning the port fitting further into the valve. Tighten the switch hand-tight and then tighten ¼-turn further using a spanner.
4. **Important:** Leak test the pressure switch connection with an FM-200 leak detector or bubbling solution. If the connection leaks, the switch may be tightened further until the leak is eliminated, again, be sure to have a counter spanner on the switch port.

4.19.1 INSTALLATION PRESSURE SWITCH B6793-908

Install the pressure switch as follows:

Note: For GCV80 valve only.

1. Hold the pressure switch fitting on the valve with a spanner, and remove the 1/8-inch plug with a second spanner. Ensure that the fitting does not rotate in the valve body. The fitting contains a check valve that will prevent the escape of the cylinder contents.
2. Before fitting the switch, apply Permacel[®] No. 412D Teflon[®] tape to the male threads of the pressure switch.
3. Install the pressure switch into the port of the valve. Be sure to secure the pressure port fitting with a spanner. Tighten the switch hand-tight and then tighten 1 1/4 -turns further using a spanner.
4. **Important:** Leak test the pressure switch connection with an FM-200 leak detector or bubbling solution. If the connection leaks, the switch may be tightened further a 1/4-turn at a time until the leak is eliminated, again, be sure to have a counter spanner on the switch port. Do not exceed two turns from hand-tight. Refer to ANSI B1.20.3 for NPT thread engagement details.

4.20 POST INSTALLATION CHECK-OUT

After the GX20 system installation has been completed, perform the following inspections and tests.

1. Verify that cylinders of correct weight and pressure are installed in accordance with installation drawings.
2. Verify that cylinder brackets and straps are properly installed and all fittings are tight.
3. The piping distribution system must be inspected for compliance with the system drawings, NFPA 2001, BS EN ISO 14520-1 and design limitations within this manual, and the computerised hydraulic calculations associated with each independent piping and nozzle configuration.
4. Check that discharge piping and actuation piping are securely hung. Ensure all fittings are tight and securely fastened to prevent agent leakage and hazardous movement during discharge. Means of pipe size reduction and installation position of tees must be checked for conformance to the design requirements.
5. The piping distribution system must be cleaned, blown free of foreign material and inspected internally to prevent the possibility of any oil or particulate matter that may soil the hazard area or affect the agent distribution due to a reduction in the effective nozzle orifice area.
6. The system piping should be pressure tested in accordance with the requirements of NFPA 2001, BS EN ISO 14520-1 and the Authority Having Jurisdiction.

WARNING

PRESSURE OPERATED CONTROL HEADS MUST BE REMOVED FROM ALL GX20 CYLINDERS PRIOR TO CONDUCTING THIS TEST TO PREVENT ACCIDENTAL DISCHARGE OF THE GX20 SYSTEM.

7. Pressure test the nitrogen actuation line for integrity and leaks, using regulated nitrogen.
8. Make sure that check valves are installed in the proper location as indicated on the installation drawings and equipment is installed with the arrow pointing in the direction of flow.
9. Verify nozzles are installed in the correct location and have the correct part number as indicated on installation drawings. Discharge nozzles must be oriented such that optimum agent dispersal can be achieved. Check nozzle orifices for obstructions.
10. The discharge nozzles, piping and mounting brackets must be installed such that they will not cause potential injury to personnel. Agent must not be discharged at head height or below, where personnel in the normal work area would be injured by the agent discharge. Agent must not directly impinge on any loose objects or shelves, cabinet tops or similar surfaces where loose objects could be propelled upon agent discharge. Ceiling tiles should be chipped in place.
11. For system with a main and reserve system capability, the main and reserve transfer switch must be properly installed, readily accessible and clearly identified.

12. Manual pull stations must be properly installed, readily accessible, and accurately identified. All manual stations used to activate GX20 systems should be properly identified as to their purpose. Particular care should be taken where manual pull stations for more than one system are in close proximity and could be confused or the wrong system actuated. In this case, manual stations should be clearly identified as to which hazard area they affect.
13. Perform electric control head test outlined in Chapter 6 on all cylinders equipped with electric control heads.
14. Perform pressure switch test outlined in Chapter 6 for all pressure switches installed.
15. All acceptance testing shall be in accordance with NFPA 2001, BS EN ISO 14520-1 current editions and the Authority Having Jurisdiction.

CHAPTER 5

OPERATION

5.1 GENERAL

Compressed FM-200 liquid is retained in the cylinder by a discharge valve. When the discharge valve is actuated by a control head, the compressed liquid agent discharges through the valve outlet and is directed through the distribution piping to the nozzles. The nozzles provide the proper flow rate and distribution of FM-200.

5.2 OPERATING PROCEDURES

5.2.1 Automatic Operation

When a system is operated automatically via the detection and control system, personnel must evacuate the hazard area promptly upon hearing the alarm. Make sure no one enters the hazard area. Call the fire brigade immediately.

5.2.2 Remote Manual Operation

Operate as follows:

1. Proceed to appropriate remote manual pull station for the hazard.
2. Operate the manual pull station.
3. Leave the hazard area quickly.
4. Allow no one to enter the hazard area. Call the fire brigade immediately.

NOTE: These instructions must be posted on display in the protected area.

5.2.3 Local Manual Operation

Operate as follows:

CAUTION

This manual control is not part of the normal system actuation and should only be used in a last resort, emergency condition.

1. Proceed to the appropriate GX20 cylinder(s) or nitrogen pilot cylinder (if used) for the hazard.
2. Remove the safety pull pin from the cylinder control head.

3. Operate the lever, following the instructions on the lever or the control head nameplate.
4. Leave the hazard area quickly.
5. Allow no one to enter the hazard area. Call the fire brigade immediately.

5.3 POST FIRE OPERATION

WARNING

DO NOT ENTER A HAZARD AREA WITH AN OPEN FLAME OR LIGHTED CIGARETTE. THE POSSIBLE PRESENCE OF FLAMMABLE VAPOURS MAY CAUSE REIGNITION OR EXPLOSION.

ENSURE FIRE IS COMPLETELY EXTINGUISHED BEFORE VENTILATING AREA. BEFORE PERMITTING ANYONE TO ENTER THE HAZARD AREA, VENTILATE AREA THOROUGHLY OR USE SELF-CONTAINED BREATHING APPARATUS.

After a FM-200 discharge, qualified fire suppression system maintenance personnel must perform post fire maintenance as directed in Chapter 6 of this manual. Observe all warnings, especially those pertaining to the length of elapsed time before entering the hazard area.

5.4 CYLINDER RECHARGE

1. Recharge all GX20 and nitrogen pilot cylinders immediately after use.
2. Return all cylinders to Kidde distributor or other qualified refill agency.
3. Refill in accordance with procedures outlined in Chapter 6 of this manual.

5.5 SPECIAL SYSTEM PRECAUTIONS

5.5.1 Systems Actuated with a Master FM-200 Cylinder

In systems where a master GX20 cylinder actuates the pressure operated control head on slave cylinders. This design permits the FM-200 pressure in the flexible actuation hoses to back-bleed into the discharge piping allowing the pressure operated control heads to automatically reset. As a precaution, before reattaching the pressure operated control head(s) to the GX20 cylinder actuation port, ensure that the actuating pin(s) are in the retracted (SET) position.

5.5.2 Systems Actuated with a Nitrogen Pilot Cylinder

Systems designed using pressure from a pilot nitrogen cylinder actuating pressure operated control heads on slave GX20 cylinders. This design traps nitrogen pressure in the pilot manifold upon system actuation and is not self-venting. Therefore, before reattaching pressure operated control heads to the recharged GX20 cylinders, the following procedure must be performed to assure that the pilot manifold is vented and the pressure operated control heads have returned to

the SET position.

1. Remove and reset master control head from the nitrogen pilot cylinder(s). This will automatically vent the pilot manifold and reset the pressure operated control heads.
2. Recharge and reinstall nitrogen pilot cylinders to the correct charge pressure and reinstall master control head.
3. Before installing pressure operated control heads on the GX20 cylinders, ensure that the actuator pin is in the retracted (SET) position.
4. Follow all other procedures and cautions as detailed in Chapter 6 of this manual.

CHAPTER 6

MAINTENANCE

WARNING

GX20 AND NITROGEN CYLINDER/VALVE ASSEMBLIES MUST BE HANDLED, INSTALLED, INSPECTED AND SERVICED ONLY BY QUALIFIED AND TRAINED PERSONNEL IN ACCORDANCE WITH THE INSTRUCTIONS CONTAINED IN THIS MANUAL AND COMPRESSED GAS REGULATIONS.

WARNING

BEFORE PERFORMING MAINTENANCE PROCEDURES, REFER TO THE SAFETY INSTRUCTIONS AND THE MATERIAL SAFETY DATA SHEETS IN APPENDIX B.

6.1 GENERAL

A regular program of systematic maintenance must be established for continuous, proper operation of all GX20 systems. Equipment must be maintained and tested in accordance with NFPA Standard 2001, BS EN ISO 14520 (current editions), and the Authority Having Jurisdiction. A periodic maintenance schedule must be followed and an inspection log maintained for ready reference. As a minimum, the log must record:

1. Inspection interval.
2. Inspection procedure performed.
3. Maintenance performed, if any, as a result of inspection.
4. Name of inspector performing task.
5. Name of organisation performing task.

If inspection indicates areas of rust or corrosion is present, immediately clean and repaint the area. Perform cylinder hydrostatic pressure testing as necessary in accordance with Section 6.4 of this manual.

NOTE: The Inspection and Retest Procedures, refer to Sections 6.3 and 6.4, are to be employed for systems that are required to satisfy FM regulations and local requirements. For those systems not requiring Factory Mutual approval, then only local standards are to be satisfied. In all cases the minimum requirement is the relevant British Standard.

6.2 PREVENTATIVE MAINTENANCE

Perform preventative maintenance, refer to Table 6.1

Table 6.1 Preventative Maintenance Schedule

Schedule	Requirement	Section
Weekly	Check GX20 cylinder pressure.	6.3.1
	Check nitrogen cylinder pressure.	6.3.1
	Hazard and enclosure inspection.	6.3.1
	Pipework and controls inspection.	6.3.1
Monthly	Inspect hazard area system components.	6.3.2
	Check GX20 cylinder weights and pressures	6.3.3
Every 6 Months	Test Pressure switches.	6.3.4.1
	Test electric control heads	6.3.4.2
Every 2 Years	Blow out distribution piping.	6.3.5
Every 5 Years	GX20 cylinder, nitrogen cylinder and flexible hose - hydrostatic pressure test and/or inspection.	6.4 and 6.10.1

6.3 INSPECTION PROCEDURES

6.3.1 Weekly

1. Check GX20 cylinder pressure gauges for proper operating pressure, see Table 2.6. If pressure gauge indicates a pressure loss (adjusted for temperature) of more than 10%, or loss in agent quantity shown on cylinder of more than 5% by mass, it shall be refilled. Remove and recharge the cylinder.
2. Check nitrogen cylinder for proper operating pressure. If pressure loss (adjusted for temperature) exceeds 10%, recharge with nitrogen to 124 bar at 21 °C (1800 PSIG at 70 °F), see Figure 6-6.
3. Visually inspect the hazard and the integrity of the enclosure for changes which may effect the performance of the system as per the requirements of BS EN ISO 14520-1.
4. Visually inspect the pipework for damage and that all operating controls and components are properly set and undamaged.

6.3.2 Monthly

1. Make a general inspection survey of all cylinders and equipment for damaged or missing parts. If equipment requires replacement, refer to Section 6.5.3.
2. Ensure access to hazard areas, manual pull stations, discharge nozzles, and cylinders are unobstructed and that there are no obstructions to the operation of the equipment or distribution of FM-200.
3. Inspect 1/4-inch flexible actuation hoses for loose fittings, damaged threads, cracks, distortion, cuts, dirt and frayed wire braid. Tighten loose fittings, replace hoses having stripped threads or other damage. If necessary, clean parts as directed in Section 6.5.1. Inspect adapters, couplings and tees at GX20 cylinder pilot outlets for tightness. Tighten couplings if necessary. Replace damaged parts.

4. Inspect GX20 cylinder pressure operated control heads for physical damage, deterioration, corrosion, distortion, cracks, dirt and loose couplings. Tighten loose couplings. Replace damaged caps. Replace control head if damage is found. If necessary, clean as directed in Section 6.5.1.
5. Inspect GX20 electric control head(s) for physical damage, corrosion, or dirt. Check control head (s) flexible electrical line for wear and damage. Check control head for loose coupling. If necessary, tighten coupling. Check that indicator is in SET position, pull pin is installed in manual lever and seal wire is intact. Replace control head if damage is found. If necessary, clean as directed in Section 6.5.1.
6. Inspect GX20 cylinder and valve assembly for leakage, physical damage such as cracks, dents, distortion, and worn parts. Check burst disc and pressure gauges for damage. If damaged, consult Kidde Fire Protection or distributor. If gauge pressure is not normal, 25 bar at 21 °C (360 PSIG at 70 °F), remove and recharge cylinder as instructed in Sections 6.6 and 6.9. If damaged parts are found on GX20 cylinder or cylinder valve, replace GX20 cylinder. If necessary, clean cylinder and associated parts as directed in Section 6.5.1.
7. Inspect GX20 cylinder brackets, straps, cradles and mounting hardware for loose, damaged or broken parts. Check cylinder brackets, straps and associated parts for corrosion, oil, grease, grime, etc. Tighten loose hardware. Replace damaged parts. If necessary, clean as directed in Section 6.5.
8. Inspect flexible discharge hoses for loose fittings, damaged threads, cracks, rust, kinks, distortion, dirt and frayed wire braid. Tighten loose fittings and replace those hoses with stripped threads. If necessary, clean as directed in Section 6.5.1.
9. Inspect nitrogen actuation line (if used) and support brackets for continuity, physical damage, loose fittings, distortion, cracks or cuts. Tighten loose fittings. Replace damaged parts. If necessary, clean as directed in Section 6.5.1.
10. Inspect discharge nozzles for dirt and physical damage. Replace damaged nozzles. If nozzles are dirty or clogged, refer to Section 6.5.2.

CAUTION

Nozzles must never be painted. A part number is located on each. Nozzles must be replaced by nozzles of the same part number. They must never be interchanged since random interchanging of nozzles could adversely affect proper FM-200 distribution and concentration level within a hazard area.

11. Inspect all manual pull stations for cracks, broken or cracked glass plate, dirt or distortion. Inspect station for signs of physical damage. Replace damaged glass. Replace station if damage is found. If necessary, clean as directed in Section 6.5.1.
12. Inspect pressure switches for deformations, cracks, dirt or other damage. Replace switch if damage is found. If necessary, clean switch as directed in Section 6.5.1.
13. Check that all personnel who may have to operate the system are properly trained and authorised to do so. All new employees must be instructed in its use.

6.3.3 Weighing GX20 Cylinders

WARNING

DISCONNECT ALL CYLINDER CONTROL HEADS, DISCHARGE HOSES, AND FLEXIBLE PILOT HOSES TO PREVENT ACCIDENTAL SYSTEM DISCHARGE.

INSTALL PROTECTION CAP ON GX20 CYLINDER VALVE ACTUATION PORT AND SAFETY CAP ON CYLINDER VALVE OUTLET PORT.

1. Remove cylinder(s) as instructed in Section 6.6
2. Place cylinder(s) on scale.
3. Record weight and date on record card and attach to GX20 cylinder. The gross weight and tare (empty) weight are metal stamped on the GX20 cylinder valve label. Therefore, subtract tare weight from the gross weight to determine net weight of original charge. Then, subtract tare weight from scale reading to determine net weight of FM-200 agent remaining in GX20 cylinder. If recorded agent net weight is less than 95% of original charge net weight, replace cylinder with fully charged GX20 cylinder, refer to Section 6.6.
4. If cylinder weight meets requirements, re-install cylinder, see Section 6.7.

6.3.3.1 Cylinders Equipped with Flexible Tape Liquid Level Indicator

Determine the FM-200 weight of 81, 142 and 243 litre cylinders equipped with graduated tape liquid level indicator as follows. This procedure can be performed without removing the GX20 cylinders from the system.

1. Remove the protective cap to expose the tape.
2. Raise the graduated tape slowly until it latches.
3. Note the reading at the point where the tape emerges from the fitting.

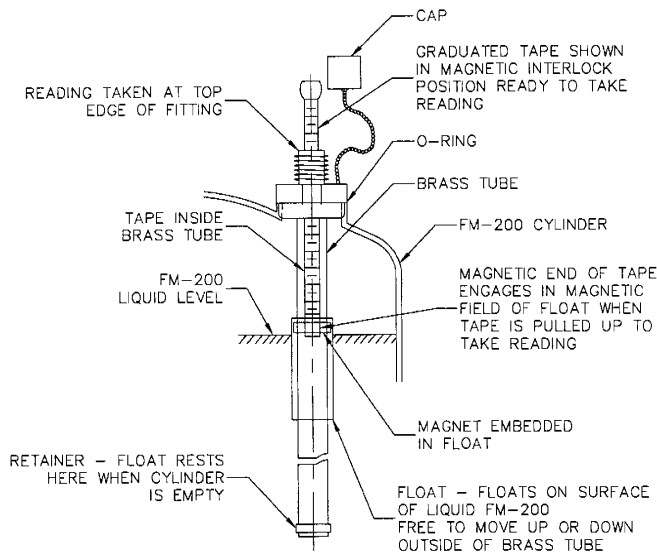

Figure 6.05. Liquid Level Indicator

4. To determine the final, more precise reading, repeat the above procedure except when a

point is reached approximately two inches before the tape is expected to latch, raise the tape very slowly until it latches.

5. While supporting the weight of the tape, record the liquid level measurement.

CAUTION

Take care not to pull the graduated tape upwards after it latches to ensure an accurate reading.

6. Check the ambient temperature where the GX20 cylinders are stored, record temperature.
7. Refer to the appropriate calibration charts, see Figures 6.1, 6.2 and 6.3, and locate the level reading on the graduated tape scale. Trace horizontally to the right to the appropriate temperature plot. Read the weight of FM-200 from the scale at the bottom of the chart. Record the weight and date on the record tag attached to the cylinder.
8. After the reading is taken, carefully push the tape down into the liquid level housing. Replace protective cap.

NOTE: If the weight measured using the liquid level indicator signifies that the cylinder should be recharged, it is recommended that the cylinder first be removed from service and the weight loss verified by using a weigh scale prior to recharging.

All GX20 cylinders must be filled or recharged by weight using a platform scale or equivalent. If weight loss is more than 5% of the FM-200 charge, the unit must be recharged.

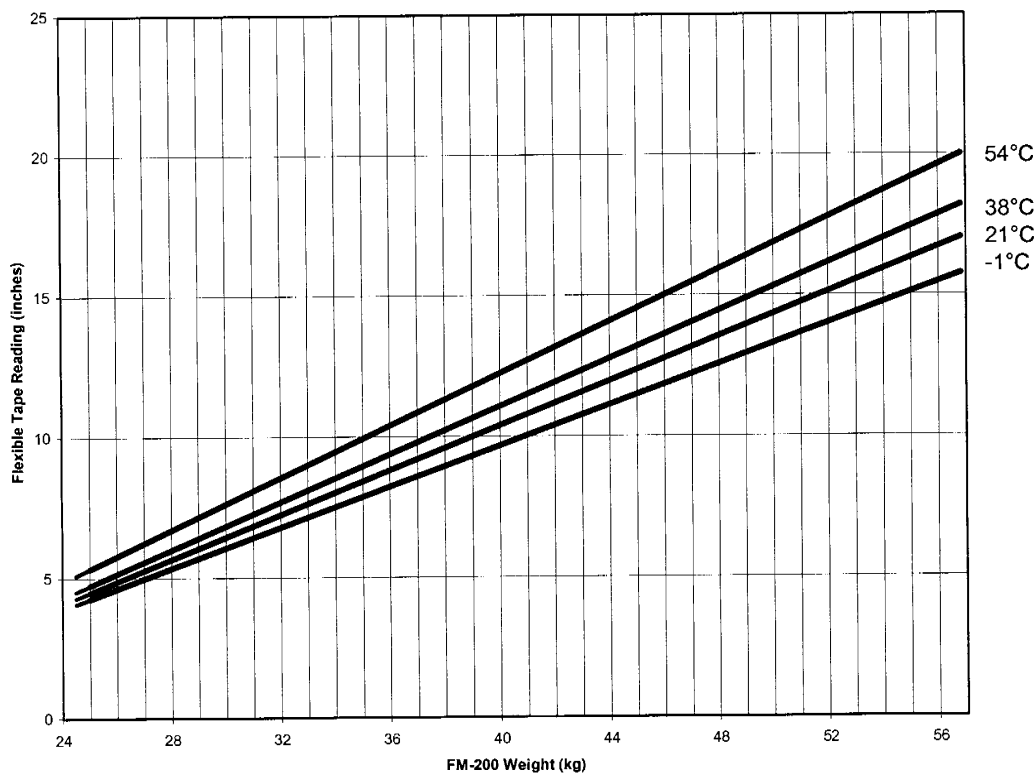

Figure 6.1 Graduated Tape Calibration Chart for 51 litre GX20 Cylinder

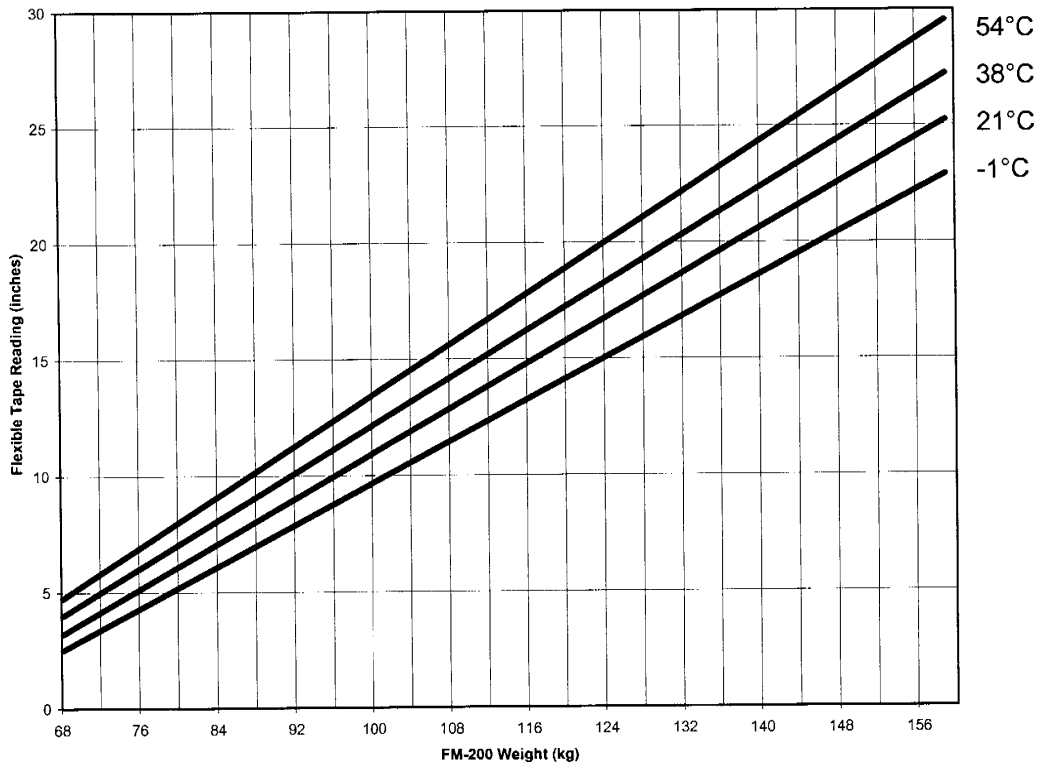

Figure 6.2 Graduated Tape Calibration Chart for 81 litre GX20 Cylinder

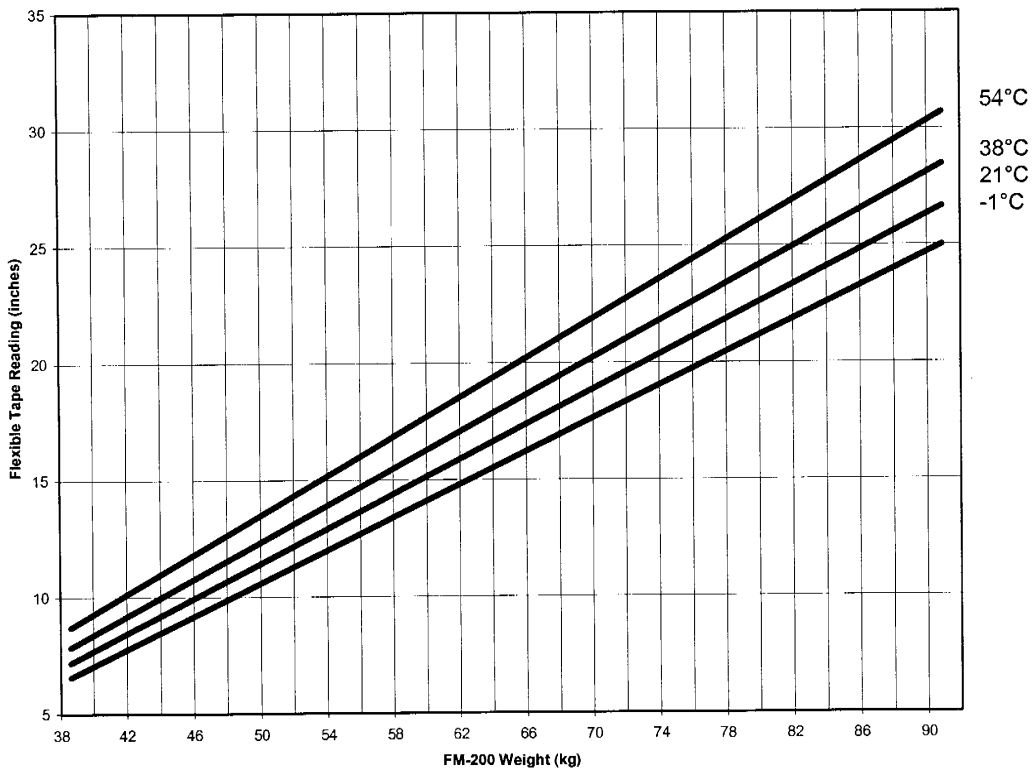

Figure 6.3 Graduated Tape Calibration Chart for 142 litre GX20 Cylinder

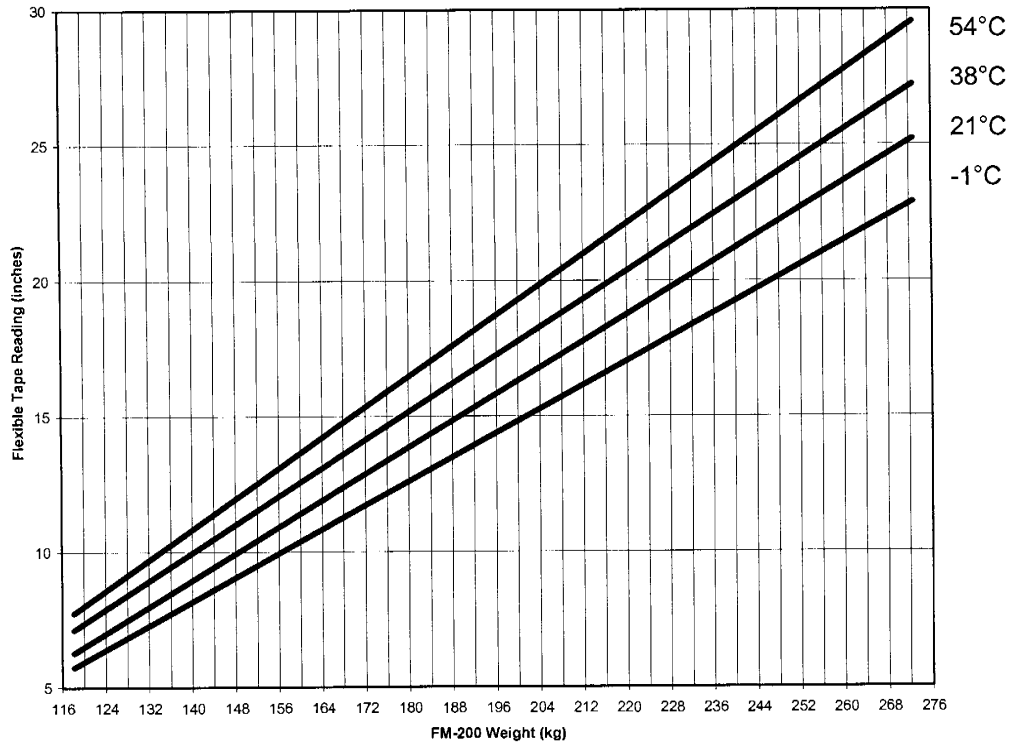

Figure 6.4 Graduated Tape Calibration Chart for 243 litre GX20 Cylinder

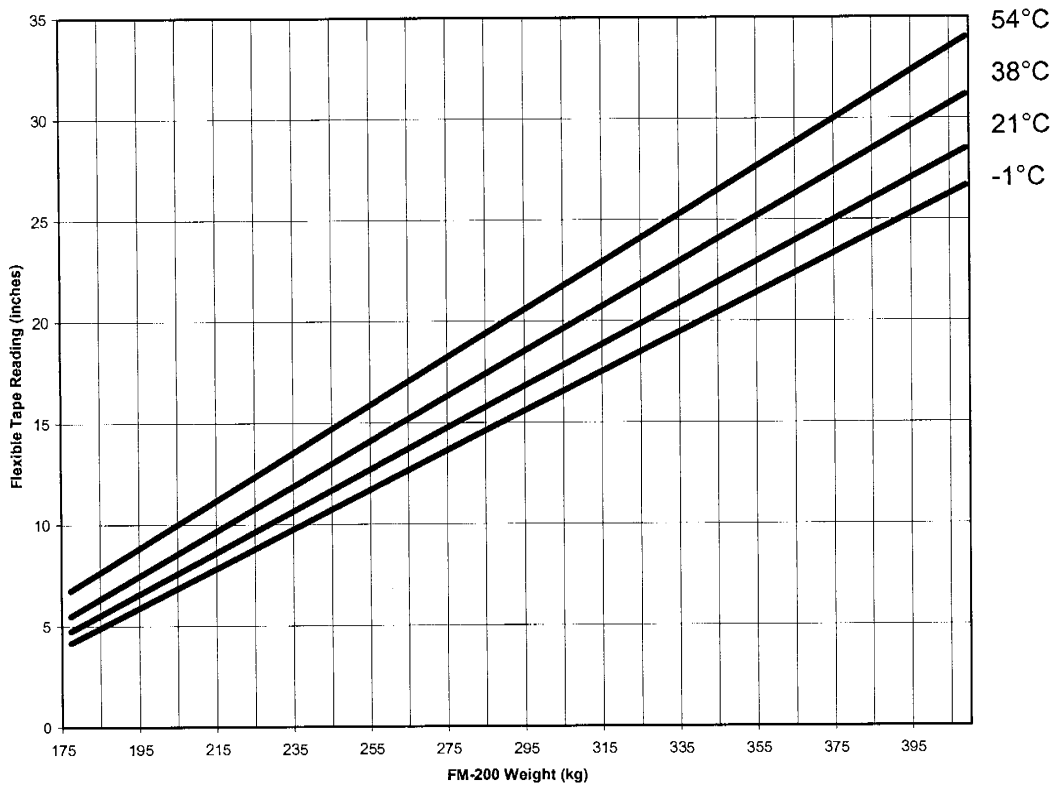

Figure 6.5 Graduated Tape Calibration Chart for 368 litre GX20 Cylinder

6.3.4 Every 6 Months

6.3.4.1 Pressure Switch Test

1. Contact appropriate personnel and obtain authorisation for shut down.
2. Ensure that hazard area operations controlled by pressure switch are operative.
3. Manually operate switch by pulling up on plunger and verify that hazard area operations controlled by pressure switch shut down.
4. Return pressure switch to SET position.
5. Re-activate all systems shut down by pressure switch, i.e. power and ventilation systems, compressors, etc.

6.3.4.2 Electric Control Head Test

CAUTION

All control heads must be removed from GX20 cylinders and nitrogen pilot cylinders prior to testing to prevent accidental cylinder discharge.

Electric control heads must be tested every six months for proper operation. This test can be performed without discharging the GX20 cylinders. Test one hazard area at a time before proceeding to the next.

1. Remove all electric control heads from all GX20 cylinders and nitrogen pilot cylinders within the hazard area being tested. Let the electric control heads hang freely from the flexible electric conduit connections. Leave all pressure operated control heads and pilot actuation hoses attached to the cylinders.
2. Operate GX20 system electrically. This can be accomplished by actuation of the GX20 system at the system control panel or by manual operation of an electric pull station.
3. Ensure all electric control heads have operated, i.e. indicator on electric control head has moved to the RELEASED position, or in the case of the stackable control head (Part No. B6793-709) observe that actuating pin has moved to its fully actuated position. If any control heads have not operated, check circuit for electric continuity to these particular heads and repeat test. Replace all damaged heads. Repeat test if any control heads have been replaced.

CAUTION

Electric control heads must be reset manually before reconnecting to the cylinder valves.

4. Observe instructions on the caution label attached to each electric control head. Replace any damaged heads which fail to reset properly before reconnecting to cylinders. Reattach all electric control heads to threaded port on cylinder valve or pressure operated control head. Tighten swivel nut securely. Make certain each electric control head is in SET position before reconnecting to cylinders. Failure to follow this procedure will result in accidental FM-200 discharge.

6.3.5 Every 2 Years

WARNING

DO NOT USE WATER OR OXYGEN TO BLOW OUT PIPE LINES. THE USE OF OXYGEN IS ESPECIALLY DANGEROUS AS THE POSSIBLE PRESENCE OF EVEN A MINUTE QUANTITY OF OIL MAY CAUSE AN EXPLOSION.

1. Remove any nozzles from piping to allow any foreign matter to blow clear.
2. Remove all pressure operated control heads from GX20 cylinders.

WARNING

DO NOT DISCONNECT PRESSURE OPERATED CONTROL HEAD. IF FM-200 ACCIDENTALLY DISCHARGES, THE UNATTACHED FLEXIBLE HOSE WILL WHIP AROUND AND MAY DAMAGE EQUIPMENT AND CAUSE SEVERE BODILY INJURY.

3. Open distributing valves and keep open long enough to ensure cleanliness of pipe.
4. Blow out all distribution piping with air or nitrogen to ensure that it is not obstructed.
5. Reconnect all control heads.

6.4 RETEST PROCEDURES

Where the visual inspection shows evidence of damage or corrosion, the cylinder shall be emptied, re-tested and re-stamped in accordance with BS EN ISO 1803 latest edition.

WARNING

CYLINDER ASSEMBLES MUST BE RETURNED WITH ALL VALVE AND DISCHARGE PROTECTION CAPS IN PLACE. THESE SHALL BE ATTACHED IMMEDIATELY AFTER DISCONNECTION FROM PIPEWORK. FAILURE TO DO SO MAY IN RESULT IN DAMAGE TO EQUIPMENT AND CAUSE SEVERE BODILY INJURY.

CAUTION

These guidelines only apply to cylinders containing FM-200.

GX20 Cylinders up to 150 ltrs are manufactured to TPED/ADR/84/527/EEC. Above 150 ltrs the assemblies are manufactured to TPED/TRG330/ADR.

6.4.1 Cylinders Continuously In Service Without Discharge

These cylinders are governed by the Transportable Pressure Equipment Directive (99/36/EC). Cylinders in continuous service without discharge require a periodic inspection in accordance with BS EN ISO 1803 latest edition. Record date of inspection on record tag attached to each cylinder. Where the visual inspection shows evidence of damage or corrosion, the cylinder shall be emptied, re-tested and re-stamped in accordance with BS EN ISO 1803 latest edition.

6.4.2 Discharged Cylinders Or Charged Cylinders That Are Transported

These cylinders are governed by the Transportable Pressure Equipment Directive (99/36/EC), or in the case of shipment of charged cylinders, other regulations may apply. In either case, cylinders in continuous service without discharge require a periodic inspection in accordance with

BS EN ISO 1803 latest edition. Record date of inspection on record tag attached to each cylinder. Where the visual inspection shows evidence of damage or corrosion, the cylinder shall be emptied, re-tested and re-stamped in accordance with BS EN ISO 1803 latest edition.

6.4.3 Retest

Cylinders used exclusively in GX20 service are required to be hydrostatically re-tested and re-stamped every ten (10) years and in accordance with BS EN ISO 1803 latest edition prior to recharge and shipment:

Inspection method	TPED/ADR/84/527/EEC		TPED/TRG330/ADR	
	First Retest Due	Subsequent Retest Due	First Retest Due	Subsequent Retest Due
Full hydrostatic test including determination of cylinder expansion.	10 years	10 years	10 years	10 years
External visual inspection per BS EN ISO 14520 requirement	6 months	6 months	6 months	6 months

6.4.4 Flexible Hoses

In accordance with the BS EN ISO 14520, all system hoses shall be examined annually for damage. If visual examination shows any deficiency, the hose shall be replaced or tested.

6.5 SERVICE

6.5.1 Cleaning

Remove dirt from metallic parts using a lint-free cloth moistened with dry cleaning solvent. Dry parts with clean, dry, lint-free cloth or air blow dry. Wipe non-metallic parts with clean, dry lint-free cloth. Remove corrosion with light abrasive cloth.

6.5.2 Nozzle Service

Service nozzles after use as follows:

1. Clean outside of nozzles with rag or soft brush.
2. Examine discharge orifices for damage or blockage. If nozzles appear to be obstructed, unscrew nozzles and clean by immersing in cleaning solvent and drying thoroughly with lint-free cloth. Replace damaged nozzles. Nozzles must be replaced with same part number in same location.

6.5.3 Repairs

Replace all damaged parts found during inspection. Replacement procedures for GX20 cylinders are in Section 6.6. For replacement for other system components refer to appropriate section of this manual for guidance.

GX20 cylinders must be recharged when cylinder pressure gauge indicates pressure is below normal (25 bar at 21 °C [360 PSIG at 70 °F]), immediately after use, or a loss in weight in excess of 5% of the original charged net weight or loss of pressure (adjusted for temperature) of more than 10%.

6.6 REMOVING GX20 CYLINDERS

WARNING

DO NOT DISCONNECT FLEXIBLE DISCHARGE HOSE OR VALVE OUTLET ADAPTOR PRIOR TO REMOVING PRESSURE AND ELECTRIC CONTROL HEADS FROM GX20 CYLINDERS. BEFORE REPLACING A GX20 CYLINDER IN A HAZARD AREA GROUP, ENSURE PILOT LINE IS COMPLETELY VENTED OF ALL PRESSURE.

6.6.1 Single Cylinder Systems

1. Remove supervisory pressure switch (where installed) and disconnect electrical connection at junction box. Unscrew switch from cylinder valve and install protection cap on switch connection port.
2. Disconnect the control head, at the swivel nut, from cylinder valve actuation port. Remove control head from GX20 cylinder.
3. Install protection cap on GX20 cylinder valve actuation port.
4. Remove valve outlet adaptor or loosen swivel nut and remove flexible discharge hose from discharge outlet port adaptor.
5. Immediately install safety cap on cylinder valve outlet port and replace the valve protection shroud.
6. Remove cylinder strap. Remove GX20 cylinder from bracket. Weigh cylinder using platform scale.

6.6.2 Multiple Cylinder Systems

WARNING

REMOVE ALL CONTROL HEADS FROM GX20 CYLINDERS.

1. Remove supervisory pressure switches (where installed) and disconnect electrical connection at junction box. Unscrew switches from cylinder valve and install protection cap on switch connection port.
2. Disconnect the control heads, at the swivel nut, from cylinder valve actuation port. Remove control heads from all GX20 cylinder valves leaving flexible actuation hose or tubing attached to the pressure operated control heads.
3. Immediately install protection cap on all GX20 cylinder valve actuation ports and replace the valve protection shrouds.
4. Remove tubing from master cylinder adaptor on master cylinder (if used).

WARNING

TO PREVENT INJURY IN THE EVENT OF DISCHARGE, MASTER CYLINDER ADAPTOR CAP MUST BE INSTALLED ON ADAPTOR WHENEVER TUBING IS NOT CONNECTED TO MASTER CYLINDER VALVE. UNDER NO CIRCUMSTANCES IS THE PROTECTION CAP TO BE REMOVED FROM ITS CHAIN.

5. Immediately install protection cap on master cylinder adaptor port.

6. Loosen swivel nut and remove flexible discharge hose from discharge outlet port.

WARNING

TO PREVENT POSSIBLE INJURY TO PERSONNEL, ALL CYLINDERS MUST HAVE SAFETY CAPS INSTALLED IMMEDIATELY IN OUTLET PORTS WHEN DISCHARGE HOSES OR VALVE OUTLET ADAPTOR IS DISCONNECTED.

7. Immediately install safety cap in cylinder valve outlet port.
8. Remove attaching hardware or cylinder straps. Remove GX20 cylinder from bracket. Weigh cylinders using platform scale.

6.7 INSTALLING GX20 CYLINDERS

6.7.1 Single Cylinder Systems

1. Position GX20 cylinder in designated location. Secure in place with cylinder strap or wall bracket and mounting hardware. Orientate cylinder with valve outlet angled toward cylinder discharge piping (refer to installation drawings).

WARNING

DISCHARGE HOSES OR VALVE OUTLET ADAPTORS MUST BE CONNECTED IN TO SYSTEM PIPING (UNION CONNECTION) BEFORE ATTACHING TO CYLINDER VALVES.

2. Remove the valve protection shroud from the cylinder and safety cap from cylinder valve outlet port. Retain the shroud and safety caps for future return of cylinders.
3. Immediately connect valve outlet adaptor or flexible discharge hose to cylinder outlet port.
4. Remove protection cap from GX20 cylinder actuation port.

WARNING

CONTROL HEAD MUST BE IN SET POSITION (THE ACTUATING PIN MUST BE IN THE FULLY RETRACTED POSITION) BEFORE ATTACHING TO CYLINDER VALVE TO PREVENT ACCIDENTAL DISCHARGE. CONTROL HEADS NOT IN THE SET POSITION WILL CAUSE DISCHARGE OF FM-200 WHEN ATTACHED ONTO THE CYLINDER VALVE.

5. Install control head.
6. If required, install supervisory pressure switch as instructed in Section 4.19.

6.7.2 Multiple Cylinder Systems

1. Position GX20 cylinders in designated location. Secure in place with cylinder straps or wall brackets and mounting hardware. Orientate cylinders with valve outlets angled towards cylinder discharge piping (refer to system installation drawings).

WARNING

DISCHARGE HOSES OR VALVE OUTLET ADAPTORS MUST BE

**CONNECTED INTO SYSTEM PIPING (UNION CONNECTION)
BEFORE ATTACHING TO CYLINDER VALVES.**

2. Sequentially remove the valve protection shroud from each cylinder and safety cap from each cylinder valve outlet port. Retain the shroud and safety caps for future return of cylinders. Repeat on completion of step 3.
3. Immediately connect flexible discharge hoses or valve outlet adaptors to cylinder valve outlet ports.
4. Remove protection cap from master cylinder adaptor port (if used) and reconnect tubing to slave port on master cylinder. Tighten swivel nut.
5. Remove protection caps from GX20 cylinder valve actuation ports.

WARNING

CONTROL HEAD MUST BE IN SET POSITION (THE ACTUATING PIN MUST BE IN THE FULLY RETRACTED POSITION) BEFORE ATTACHING TO CYLINDER VALVE TO PREVENT ACCIDENTAL DISCHARGE. CONTROL HEADS NOT IN THE SET POSITION WILL CAUSE DISCHARGE OF FM-200 WHEN ATTACHED ONTO THE CYLINDER VALVE.

6. Install electric and pressure operated control heads with flexible actuation hoses or tubing on cylinder valve actuation ports. Tighten swivel nuts.
7. If required, install supervisory pressure switches as instructed in Section 4.19.

6.8 POST FIRE MAINTENANCE

After the system has discharged, **DO NOT ATTEMPT TO RESUME OPERATIONS IN THE FIRE AREA.** Contact an approved Kidde Fire Protection distributor to reset and recharge your system. Insist that the system be recharged immediately and only with the proper type and quantity of agent.

6.9 RECHARGING GX20 CYLINDERS

CAUTION

GX20 cylinders may require retest before recharge, refer to Section 6.4.

CAUTION

The following must only be carried out by a Kidde Fire Protection approved filling station:

1. **RECHARGING GX20 CYLINDERS.**
2. **LEAK TESTING OF GX20 CYLINDERS.**
3. **SALVAGING FM-200.**

6.10 NITROGEN PILOT CYLINDER SERVICE AND MAINTENANCE

WARNING

ANY AREA IN WHICH NITROGEN IS USED OR STORED MUST BE PROPERLY VENTILATED. A PERSON WORKING IN AN AREA WHERE AIR HAS BECOME ENRICHED WITH NITROGEN CAN BECOME UNCONSCIOUS WITHOUT SENSING THE LACK OF OXYGEN. REMOVE VICTIM TO FRESH AIR. ADMINISTER ARTIFICIAL RESPIRATION IF NECESSARY AND SUMMON A DOCTOR. NEVER DISPOSE OF LIQUEFIED NITROGEN IN AN INDOOR WORK OR STORAGE AREA.

Nitrogen cylinders must be recharged when cylinder pressure gauge indicates pressure is below normal (124 bar at 21° C [1800 PSIG at 70°F]) or as adjusted for temperature as shown on Figure 6.6 or immediately after discharge. Contact an approved Kidde Fire Protection distributor to recharge and maintain your cylinder.

6.10.1 Hydrostatic Pressure Test

These cylinders are governed by the Transportable Pressure Equipment Directive (99/36/EC), or in the case of shipment of charged cylinders, other regulations may apply. In either case, cylinders in continuous service without discharge require a periodic inspection in accordance with BS EN ISO 1968 latest edition. Record date of inspection on record tag attached to each cylinder. Where the visual inspection shows evidence of damage or corrosion, the cylinder shall be emptied, re-tested and re-stamped in accordance with BS EN ISO 1968 latest edition.

6.10.2 Replacement

WARNING

WHEN REMOVING A PRESSURISED CYLINDER THE CONTROL HEAD LEVER MUST BE IN THE CLOSED POSITION WITH SAFETY PULL PIN INSTALLED. A CONTROL HEAD LEVER IN THE OPEN POSITION WILL RESULT IN DISCHARGE OF REMAINING CONTENTS OF CYLINDER, RESULTING IN SYSTEM ACTIVATION, PROPERTY DAMAGE OR POSSIBLE BODILY INJURY.

Replace the nitrogen cylinder, when expended or due to pressure loss, as follows:

1. Remove control head from nitrogen cylinder valve.
2. Immediately install protection cap on nitrogen cylinder actuation port.
3. Remove flexible actuation hose or tubing and adaptor (Part No. B6793-773) from cylinder valve outlet and install safety plug.
4. Remove clamps and hardware securing nitrogen cylinder to mounting bracket.

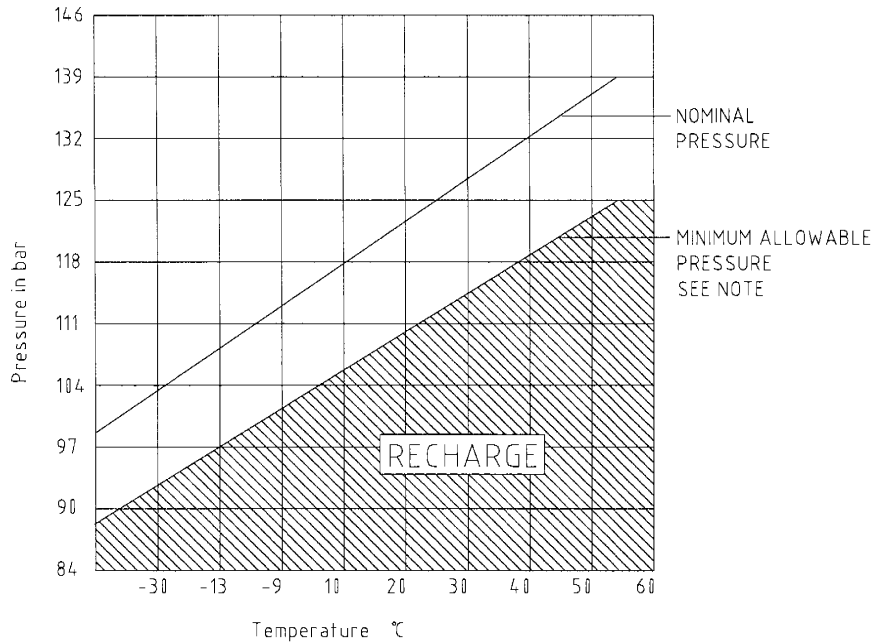

Figure 6.6 Nitrogen Pressure versus Temperature Data

6.10.4 Installation

1. Install nitrogen cylinder in position in mounting bracket.
2. Tighten sufficiently to hold cylinder in place while allowing cylinder enough free play to be manually rotated.
3. Manually rotate cylinder until cylinder valve discharge outlet is in desired position.

CAUTION

Nitrogen cylinder must be positioned so that control head, when installed, is readily accessible and cannot be obstructed during manual operation.

4. Securely tighten mounting bracket clamps and hardware.
5. Remove pipe plug, reconnect adaptor (Part No. B6793-773) and flexible actuation hose or tubing to cylinder valve outlet port.
6. Remove protective cap from cylinder valve actuation port.

WARNING

ENSURE CONTROL HEAD IS IN THE SET POSITION. FAILURE TO POSITION CONTROL HEAD IN SET POSITION WILL CAUSE DISCHARGE OF NITROGEN CYLINDER UPON CONTROL HEAD INSTALLATION.

5. Install control head to cylinder valve and tighten securely.

CHAPTER 7

APPROVED SYSTEM COMPONENTS

This section contains lists of components and part numbers for Kidde Fire Protection GX20 Engineered FM-200 Fire Suppression Systems.

7.1 APPROVED SYSTEM COMPONENTS

7.1.1 GX20 Cylinder/Valve Assemblies

Vertical Mount Only	Part No.
5 litre cylinder complete with GCV40 valve	E7763-101-01-EU
8 litre cylinder complete with GCV40 valve	E7763-102-01-EU
16 litre cylinder complete with GCV40 valve	E7763-103-01-EU
28 litre cylinder complete with GCV40 valve	E7763-104-01-EU
51 litre cylinder complete with GCV40 valve	E7763-105-01-EU
81 litre cylinder complete with GCV50 valve	E7763-106-05-EU
81 litre cylinder complete with liquid level indicator and GCV50 valve	E7763-107-02-EU
142 litre cylinder complete with GCV50 valve	E7763-108-01-EU
142 litre cylinder complete with liquid level indicator and GCV50 valve	E7763-109-01-EU
243 litre cylinder complete with GCV65 valve	E7763-110-01
243 litre cylinder complete with liquid level indicator and GCV65 valve	E7763-111-01
243 litre cylinder complete with GCV80 valve	E7763-110-05-EU
243 litre cylinder complete with liquid level indicator and GCV80 valve	E7763-111-05-EU
368 litre cylinder complete with GCV80 valve	E7763-112-01-EU
368 litre cylinder complete with liquid level indicator and GCV80 valve	E7763-113-01-EU

7.1.2 Flexible Discharge Hoses

Where Used	Part No.
5, 8, 16, 28 and 51 litre cylinders with GCV40	B6793-760
81 and 142 litre cylinders with GCV50	B6793-761
243 litre cylinders with GCV65	B6793-763
243 and 368 litre cylinders with GCV80 – Groove to NPT	D7715-037
243 and 368 litre cylinders with GCV80 – Groove to Groove	D7715-038

7.1.3 Valve Outlet Adaptors

Where Used	NPT Part No.	BSP Part No.
5, 8, 16, 28 and 51 litre cylinders	283904	K63497-02
81 and 142 litre cylinders	283905	K63497-03
243 litre cylinders with GCV65	283906	K63497-04
243 and 368litre cylinders with GCV80	B6782-182	B6782-177

7.1.4 Cylinder Straps And Bracket U-straps

Where Used	Part No.
5 and 8 litre cylinders	C6331-103
16 and 28 litre cylinders	C6331-104
51 and 81litre cylinders	C6331-105-02
142 litre cylinders	C6331-106
243 litre cylinders	C6331-107
368 litre cylinders	C6331-121

7.1.5 Brackets, Wall Mounting

Where Used	Part No.
5 litre cylinders	D1162-001
8 litre cylinders	D1162-002
16 litre cylinders	D1162-003
28 litre cylinders	D1162-004

7.1.6 Cradles

Where Used	Part No.
51 to 81 litre cylinders	C6331-122
142 litre cylinders	C6331-124
243 litre cylinders	C6331-126

7.1.7 Front Clamp

Where Used	Part No.
51 to 81 litre cylinders	C6331-123
142 litre cylinders	C6331-125
243 litre cylinders	C6331-127

7.1.8 Control Heads

Description	Part No.
Electric, Standard, 24 V d.c	B6793-701
Electric/Cable, Standard, 24 V d.c	B6793-702
Electric/Cable, Explosion Proof, 24 V d.c	B6793-703
Cable Operated	B6793-704
Lever Operated	B6793-705
Lever/Pressure Operated	B6793-706
Pressure Operated	B6793-707
Pressure Operated Stackable	B6793-708
Electric, Stackable, 24 V d.c	B6793-709
Electric, Standard, 115 V a.c *	B6793-787
Electric Cable, Standard, 115 V a.c *	B6793-789
Electric/Cable, Explosion Proof, 115 V a.c *	B6793-788
Electric, Stackable, Explosion Proof, 24 V d.c	B6793-859

* Note: UL Listed but not FM Approved for use with FM-200 systems

7.1.9 Pressure Control Equipment

Description	Part No.
Master Cylinder Adaptor Kit	B6793-770
Male Branch Tee, 5/16 inch flare by 1/8 inch NPT	B6793-775
Male Elbow, 5/16 inch flare by 1/8 inch NPT	B6793-774
Male Connector, 5/16 inch flare by 1/8 inch NPT	B6793-773
Actuation Hose, 559 mm (5, 8, 16, 28, 51 and 81 litre cylinders)	B6793-771
Actuation Hose, 762 mm (142, 243 and 368 litre cylinders)	B6793-772
Nitrogen Pilot Cylinder	B6793-720
Mounting Bracket for Nitrogen Pilot Cylinder	B6793-721
1/4 inch Check Valve	B6793-786
Safety Outlet, FM-200	B6793-740
Safety Outlet, N ₂ /CO ₂	803242

7.1.10 Control Equipment, Cable Operated

Description	Part No.
Pull Box, Break Glass	B6793-782
Corner Pulley, Watertight	B6793-783
Corner Pulley, 1/2 inch EMT	B6793-784
1/16 inch Cable	B6793-785

7.1.11 Auxiliary Equipment

Description	Part No.
Supervisory Pressure Switch for GCV40,50 and 65	06-118262-001
Supervisory Pressure Switch for GCV80 only	B6793-908
Pressure Operated Switch, Standard	B6793-731
Pressure Operated Switch, Explosion Proof	B6793-732
Pressure Trip	B6793-733
Transfer Switch, Main to Reserve	B6793-790

7.1.12 Check Valves

Description	Part No.
Elbow Check 50mm NB (2" NPT)	B6793-762
Elbow Check 65mm NB (2.5" NPT)	B6793-764
Swing Check 50mm NB (2" NPT)	B6793-805
Swing Check 80mm NB (3" NPT)	B6793-869
Check Valve 15mm NB (1/2" NPT)	B6793-806
Check Valve 20mm NB (3/4" NPT)	B6793-807
Check Valve 25mm NB (1" NPT)	B6793-808
Check Valve 32mm NB (1 1/4" NPT)	B6793-809
Check Valve 40mm NB (1 1/2" NPT)	B6793-810
Check Valve 50mm NB (2" NPT)	B6793-811
Check Valve 80mm NB (3" NPT)	B6793-812

7.1.13 Discharge Nozzles

WARNING

ONLY LISTED KIDDE FIRE PROTECTION FM-200 NOZZLES ARE TO BE USED ON KIDDE GX20 SYSTEMS. FAILURE TO COMPLY WITH THIS WARNING CAN RESULT IN UNPREDICTABLE AGENT DISTRIBUTION.

Nozzle Size (mm)	BSP Part No.	NPT Part No.	Discharge Characteristics
15 (1/2 inch)	C3333-301-XX	C3333-328-XX	180°
20 (3/4 inch)	C3333-302-XX	C3333-329-XX	180°
25 (1 inch)	C3333-303-XX	C3333-330-XX	180°
32 (1-1/4 inch)	C3333-304-XX	C3333-331-XX	180°
40 (1-1/2 inch)	C3333-305-XX	C3333-332-XX	180°
50 (2 inch)	C3333-306-XX	C3333-333-XX	180°
15 (1/2 inch)	C3333-307-XX	C3333-334-XX	360°
20 (3/4 inch)	C3333-308-XX	C3333-335-XX	360°
25 (1 inch)	C3333-309-XX	C3333-336-XX	360°
32 (1-1/4 inch)	C3333-310-XX	C3333-337-XX	360°
40 (1 1/2 inch)	C3333-311-XX	C3333-338-XX	360°
50 (2 inch)	C3333-312-XX	C3333-339-XX	360°

NOTE: XX in the Part No. refers to the Drill Code.

180 degree Nozzles						
Ratio of nozzle area to pipe area			0.66 to 0.27			
BSP	15	20	25	32	40	50
KFP Ref No.	1/2"	3/4"	1"	1 1/4"	1 1/2"	2"
109	C3333-301-22					
111	C3333-301-23					
113	C3333-301-24					
116	C3333-301-25					
120	C3333-301-26					
125	C3333-301-27					
129	C3333-301-28					
136	C3333-301-29					
141	C3333-301-30					
144	C3333-301-31	C3333-302-21				
147	C3333-301-32	C3333-302-22				
150	C3333-301-33	C3333-302-23				
156	C3333-301-34	C3333-302-24				
161	C3333-301-35	C3333-302-25				
166	C3333-301-36	C3333-302-26				
172	C3333-301-37	C3333-302-27				
177		C3333-302-28				
180		C3333-302-29				
182		C3333-302-30	C3333-303-22			
185		C3333-302-31	C3333-303-23			
189		C3333-302-32	C3333-303-24			
194		C3333-302-33	C3333-303-25			
199		C3333-302-34	C3333-303-26			
206		C3333-302-35	C3333-303-27			
213		C3333-302-36	C3333-303-28			
219		C3333-302-37	C3333-303-29			
221		C3333-302-38	C3333-303-30			

KFP Ref No.	1/2"	3/4"	1"	1 1/4"	1 1/2"	2"
228		C3333-302-39	C3333-303-31			
234			C3333-303-32			
238			C3333-303-33			
246			C3333-303-34	C3333-304-21		
250			C3333-303-35	C3333-304-22		
257			C3333-303-36	C3333-304-23		
261			C3333-303-37	C3333-304-24		
266			C3333-303-38	C3333-304-25		
272			C3333-303-39	C3333-304-26		
277			C3333-303-40	C3333-304-27		
290			C3333-303-41	C3333-304-28	C3333-305-21	
295				C3333-304-29	C3333-305-22	
302				C3333-304-30	C3333-305-23	
313				C3333-304-31	C3333-305-24	
316				C3333-304-32	C3333-305-25	
323				C3333-304-33	C3333-305-26	
328				C3333-304-34	C3333-305-27	
332				C3333-304-35	C3333-305-28	
339				C3333-304-36	C3333-305-29	
344				C3333-304-37	C3333-305-30	
358				C3333-304-38	C3333-305-31	C3333-306-21
359				C3333-304-39	C3333-305-32	C3333-306-22
368				C3333-304-40	C3333-305-33	C3333-306-23
375				C3333-304-41	C3333-305-34	C3333-306-24
377				C3333-304-42	C3333-305-35	C3333-306-25
386				C3333-304-43	C3333-305-36	C3333-306-26
391					C3333-305-37	C3333-306-27
397					C3333-305-38	C3333-306-28
404					C3333-305-39	C3333-306-29

KFP Ref No.	1/2"	3/4"	1"	1 1/4"	1 1/2"	2"
413					C3333-305-40	C3333-306-30
422					C3333-305-41	C3333-306-31
438					C3333-305-42	C3333-306-32
453						C3333-306-33
469						C3333-306-34
484						C3333-306-35
500						C3333-306-36
516						C3333-306-37
531						C3333-306-38
547						C3333-306-39
563						C3333-306-40
578						C3333-306-41

360 degree Nozzles						
Ratio of nozzle area to pipe area			0.72 to 0.27			
BSP	15mm	20mm	25mm	32mm	40mm	50mm
KFP Ref No.	1/2"	3/4"	1"	1 1/4"	1 1/2"	2"
111	C3333-307-23					
113	C3333-307-24					
116	C3333-307-25					
120	C3333-307-26					
125	C3333-307-27					
129	C3333-307-28					
136	C3333-307-29					
141	C3333-307-30					
144	C3333-307-31					
147	C3333-307-32	C3333-308-22				
150	C3333-307-33	C3333-308-23				

KFP Ref No.	1/2"	3/4"	1"	1 1/4"	1 1/2"	2"
156	C3333-307-34	C3333-308-24				
161	C3333-307-35	C3333-308-25				
166	C3333-307-36	C3333-308-26				
172	C3333-307-37	C3333-308-27				
177	C3333-307-38	C3333-308-28				
180	C3333-307-39	C3333-308-29				
182	C3333-307-40	C3333-308-30				
185	C3333-307-41	C3333-308-31				
189		C3333-308-32	C3333-309-24			
194		C3333-308-33	C3333-309-25			
199		C3333-308-34	C3333-309-26			
206		C3333-308-35	C3333-309-27			
213		C3333-308-36	C3333-309-28			
219		C3333-308-37	C3333-309-29			
221		C3333-308-38	C3333-309-30			
228		C3333-308-39	C3333-309-31			
234		C3333-308-40	C3333-309-32			
238		C3333-308-41	C3333-309-33			
246			C3333-309-34	C3333-310-21		
250			C3333-309-35	C3333-310-22		
257			C3333-309-36	C3333-310-23		
261			C3333-309-37	C3333-310-24		
266			C3333-309-38	C3333-310-25		
272			C3333-309-39	C3333-310-26		
277			C3333-309-40	C3333-310-27		
290			C3333-309-41	C3333-310-28	C3333-311-21	
295			C3333-309-42	C3333-310-29	C3333-311-22	
302			C3333-309-43	C3333-310-30	C3333-311-23	
313			C3333-309-44	C3333-310-31	C3333-311-24	

KFP Ref No.	1/2"	3/4"	1"	1 1/4"	1 1/2"	2"
316				C3333-310-32	C3333-311-25	
323				C3333-310-33	C3333-311-26	
328				C3333-310-34	C3333-311-27	
332				C3333-310-35	C3333-311-28	
339				C3333-310-36	C3333-311-29	
344				C3333-310-37	C3333-311-30	
358				C3333-310-38	C3333-311-31	
359				C3333-310-39	C3333-311-32	
368				C3333-310-40	C3333-311-33	C3333-312-23
375				C3333-310-41	C3333-311-34	C3333-312-24
377				C3333-310-42	C3333-311-35	C3333-312-25
386				C3333-310-43	C3333-311-36	C3333-312-26
391				C3333-310-44	C3333-311-37	C3333-312-27
397				C3333-310-45	C3333-311-38	C3333-312-28
404				C3333-310-46	C3333-311-39	C3333-312-29
413					C3333-311-40	C3333-312-30
422					C3333-311-41	C3333-312-31
438					C3333-311-42	C3333-312-32
453					C3333-311-43	C3333-312-33
469					C3333-311-44	C3333-312-34
484						C3333-312-35
500						C3333-312-36
516						C3333-312-37
531						C3333-312-38
547						C3333-312-39
563						C3333-312-40
578						C3333-312-41
594						C3333-312-42
609						C3333-312-43

7.2 CONDITIONS OF SALE

Kidde Fire Protection Services LTD

- 1.0 In these Conditions, the Seller means KIDDE FIRE PROTECTION SERVICES LTD, the Particulars of Contract are the details of the Contract set out overleaf, the Buyer and the Goods are respectively the person and the products specified in the Particulars of Contract as such. Appointed Person means a director or appointed manager of the Seller, and the Contract means the Contract for the sale of the Goods by the Seller to the Buyer comprising the Particulars of Contract and these Conditions. These Conditions shall apply to all contracts of sale with the Seller in relation to the goods and services supplied by the Seller.

Formation and Parties

- 2.0 No express terms other than those contained in these Conditions and the Particulars of Contract shall be part of the Contract, and the Contract may only be varied in writing by an Appointed Person. No representations or warranties relating to the Goods or advice or recommendation on the use of the Goods are binding on the Seller unless confirmed by the Seller in writing in response to a written request of the Buyer specifically referring to this Condition.
- 2.1 The Contract may be cancelled by the Buyer only with the Seller's written consent which, if given, shall be on the express condition that the Buyer shall pay to the Seller a cancellation charge commensurate with the Seller's costs incurred up to the date of cancellation plus the Seller's loss of profit or, at the Seller's option, a sum equal to ten per cent of the Contract Price.
- 2.2 Unless otherwise specified, quotations made by the Seller shall automatically lapse if no order is received by the Seller within 30 days of the date of quotation. None of the Seller's distributors, agents or employees are authorised to conclude contracts orally or over the telephone, and quotations, statements in price lists, or sales literature and advertisements do not constitute offers. No contract for the sale of Goods shall be concluded until the Seller has accepted an order of the Buyer by sending to the Buyer an Acknowledgement of Order signed by an Appointed Person.
- 2.3 The Buyer warrants that all information which it has given to the Seller prior to entering into the Contract is true and correct and the Seller reserves all its rights where it subsequently discovers such information is incorrect.

Delivery

- 3.0 If any delivery time is specified in the Particulars of Contract, this period shall commence on the later of the date of the Seller's written Acknowledgement of Order and the date the Seller receives all the information necessary to allow it to proceed without interruption, or if the Buyer requests any variation to the Contract, the date of the Seller's written confirmation of its agreement to such variation.
- 3.1 Although the Seller will endeavour to complete the Contract within any specified delivery time or by any specified delivery date, that time or date is an estimate only and the Seller shall not be liable for any reasonable delay in delivery.
- 3.2 Any delivery time specified shall (in any event) be extended by any period or periods of Force Majeure during which the manufacture or delivery of the goods by the Seller under the Contract is delayed owing to fire, explosion, flood, storm, sabotage, strikes (official and unofficial), riot, acts of war (whether war be declared or not) shortage of labour, power, or materials, delay by the Seller's suppliers, civil commotion, accidents, plant breakdowns, technical difficulties connected with the manufacture or adaptation of the Goods to the Buyer's design or specification, seizure or other action by or compliance with an order of an apparently competent authority and any other event or circumstance beyond the control of the Seller.
- 3.3 The Seller shall be entitled to withhold delivery of any Goods if at the time delivery is to be made payment is due by the Buyer to the Seller on any account whatsoever.
- 3.4 The delivery of a greater or lesser quantity of the Goods than the quantity ordered, of other Goods not ordered, or of Goods only some of which are defective, shall not entitle the Buyer to reject Goods that were ordered and are not defective.
- 3.5 Unless otherwise stated, delivery shall be deemed to take place when the Goods are delivered to the delivery address specified in the Particulars of Contract or if not so specified, at the principal place of business of the Buyer known to the Seller.
- 3.6 If the Buyer fails to accept delivery of the Goods in accordance with the Contract the Seller may (without prejudice to its other rights against the Buyer) store the Goods at the sole risk and cost of the Buyer.
- 3.7 The Buyer shall inspect the Goods immediately on delivery thereof and shall within five days from such delivery give notice to the Seller of any matter or thing by reason thereof the Buyer may allege that the goods are not in accordance with the Contract or are defective in material or workmanship. If the Buyer shall fail to give such notice the Goods shall be conclusively presumed to be in all respects in accordance with the Contract and free from any defect which would be apparent on reasonable examination of the Goods and the Buyer shall, as between the Buyer and the Seller, be deemed to have accepted the Goods accordingly.
- 3.8 The Seller reserves the right to make delivery by instalments and invoice and be paid for each installment separately. Each installment shall be deemed to constitute a separate agreement subject to the terms of the Contract and no failure of or delay in delivery of any installment nor any defect in the contents thereof shall entitle the Buyer to treat the Contract as repudiated with regard to any remaining instalments.

Retention of Title

- 4.0 Notwithstanding delivery, title to the Goods shall not pass to the Buyer until all sums due on any account whatever by the Buyer to the Seller have been paid in full. Until such time the Buyer will hold the Goods as bailee of and in a fiduciary capacity for the Seller and will:
- (i) keep the Goods marked or stored separately from other goods, so as to be identifiable as the property of the Seller;
 - (ii) deliver the Goods up to the Seller on demand; and
 - (iii) permit the Seller or its agents to enter upon the Buyer's premises in order to retake possession of the Goods.
- 4.1 Notwithstanding that the property in all Goods to be delivered to the Buyer by the Seller will remain vested as aforesaid until the Seller has received payment in full therefor, the risk of damage to or loss of all or any such Goods will pass to the Buyer upon delivery in accordance with the Contract unless the Buyer shall fail to accept delivery whereupon the risk shall pass to the Buyer on the earliest date on which the delivery could have been made but for such failure on the part of the Buyer.

Price

- 5.0 Unless otherwise stated in the Particulars of Contract, the Contract prices for the Goods shall be:
- (i) exclusive of VAT, taxes or duties levied on the Seller in the Buyer's country for which the Seller shall be entitled to make additional charges, and shall be exclusive of the costs of delivery and associated packaging and insurance costs which shall be charged separately.
 - (ii) subject to increase by the Seller to reflect any variation in the delivery schedule for or design, quantities or specifications of the Goods made at the request of the Buyer or any delay caused by the failure of the Buyer to provide adequate information or instructions to the Seller.

Payment

- 6.0 Unless otherwise specified in the Particulars of Contract payment for the Goods shall be made in full within 30 days of the date of invoice. Time of payment shall be of the essence. If the Buyer fails to make any payment on the due date then, without prejudice to any other right or remedy available to the Seller, the Seller shall be entitled to suspend any further deliveries to the Buyer, appropriate any payment made by the Buyer to such of the Goods (or the Goods supplied under any other contract between the Buyer and the Seller) as the Seller may think fit (notwithstanding any purported appropriation by the Buyer) charge the Buyer interest (both before and after any judgement) on the amount unpaid at the rate of 4 per cent per annum above Barclays Bank plc base rate from time to time and exercise a lien over any property of the Buyer then in its possession, until payment in full is made.
- 6.1 Save as aforesaid payments shall be applied to invoices in the order in which they were issued and to Goods in the order in which they are listed in invoices.
- 6.2 The Buyer shall not be entitled to make any deduction or withhold any sum from the payment from time to time due from it whether by way of set-off, counter claim or otherwise.

Warranty

- 7.0 The Seller warrants for a period of 12 months from invoice date that, in so far as the Goods are of its own manufacture, they shall be free from defects in workmanship or materials at the time of delivery. If any Goods do not conform to that warranty the Seller will at its option:
- (a) replace the Goods found not to conform to the warranty and such replacements shall be supplied subject to these Conditions; or
 - (b) take such steps as the Seller deems necessary to bring the Goods into a state where they are free from such defects; or
 - (c) take back the Goods found not to conform to the warranty and refund the appropriate part of the purchase price.
- PROVIDED THAT:**
- (i) the liability of the Seller shall not arise unless the Buyer demonstrates to the Seller's reasonable satisfaction that the Goods have, prior to use, been properly stored and handled and subsequently have not been used in any unusual or abnormal way or in a manner contrary to any instructions or recommendations for use provided by the Seller;
 - (ii) the liability of the Seller shall in no event exceed the purchase price of the Goods;
 - (iii) performance of any one of the above options (as limited by (ii) above) shall constitute an entire discharge of the Seller's liability under this warranty.
- 7.1 The foregoing warranty is conditional upon:
- (a) the Buyer giving written notice to the Seller of the alleged defect in the Goods, such notice to be received by the Seller within 7 days of the time when the Buyer discovers or ought to have discovered the defect and in any event within one year of delivery of the Goods;
 - (b) the Buyer affording the Seller a reasonable opportunity to inspect the Goods and, if so requested by the Seller, returning the allegedly defective Goods to the Seller's works, carriage pre-paid, for inspection to take place there;

- (c) the Buyer making no further use of the Goods that are alleged to be defective after the time at which the Buyer discovers or ought to have discovered that they are defective.
- 7.2 The Seller further undertakes that, in so far as the Goods are not of its own manufacture, it will pass on to the Buyer the benefit of any guarantees or indemnities given to it in respect of such Goods by its own suppliers.
- 7.3 Save as provided in paragraphs 1 and 3 of this clause, in clause 2 and in section 12 of the Sale of Goods Act 1979:
- (i) all conditions and warranties, express or implied, as to the quality or fitness for any purpose of the Goods are hereby expressly excluded; and
 - (ii) except in respect of death or personal injury caused by the Seller's negligence, or in respect of liability under the Consumer Protection Act 1987, the Seller shall not be liable for any loss or damage (whether direct, indirect or consequential) howsoever arising which may be suffered by the Buyer.

It is hereby expressly declared that any statements as to quality made by the Seller do not form part of the description of the Goods.

Limits of Liability

- 8.0 The Buyer must satisfy itself of the suitability of the Goods for the purposes for which they are purchased, and must comply with any directions, instructions or warnings as to the use storage or handling of the Goods given by the Seller. The Buyer must also ensure that the Goods comply with all local approvals and standards relating to the use to which they are to be put, and without prejudice to the generality of paragraph 3 above, all recommendations and advice given by or on behalf of the Seller to the Buyer as to the methods of storing, applying or using the Goods the purposes to which the Goods may be applied and the suitability of using the Goods in any manufacturing process or in conjunction with any other materials are (except when given pursuant to a request of the Buyer under clause 2) given without liability on the part of the Seller, its servants or agents.
- 8.1 In the event that, notwithstanding the provisions of paragraphs 7.3 and 8.0 above, the Seller is found liable for any loss or damage suffered by the Buyer, that liability shall in no event exceed the purchase price of the Goods.
- 8.2 Nothing in these Conditions or in the Particulars of Contract shall affect or limit the validity or application of any customer warranty with the benefit of which any of the Goods are sold and if the Buyer, being an end-user, is able to benefit from such a warranty the terms thereof shall prevail over the terms of these Conditions and the Particulars of Contract.

Bankruptcy and Liquidation

- 9.0 This clause applies if the Buyer becomes (or appears to the Seller to be about to become) bankrupt, or goes (or appears to the Seller to be about to go) into liquidation, has a petition presented or threatened for its winding-up, suspends payment of debts or makes any arrangement with creditor, fails to pay in accordance with the terms of the Contract, has an administration order made or a petition for such an order presented or threatened, has a receiver appointed over all or any part of its assets or is answerable under the law of the country having jurisdiction over the Buyer or its assets for any of the foregoing, or is in breach of any other term of the Contract.
- 9.1 If this clause applies, then without prejudice to any other right or remedy available to the Seller, the Seller shall be entitled to cancel the Contract or suspend any further deliveries under the Contract without liability to the Buyer, and if the Goods have been delivered but not paid for the price shall become immediately due and payable notwithstanding any previous agreement or arrangement to the contrary.

Indemnities

- 10.0 The Buyer shall indemnify the Seller in respect of all damage injury or loss occurring to any person or property and against all actions, suits, claims, demands, charges or expenses in connection therewith arising from the condition or use of the Goods in the event that the damage injury or loss shall have been occasioned partly or wholly by the carelessness of the Buyer and his servants, contractors or agents or by any breach by the Buyer of either its obligations to the Seller hereunder or of any patent, design or other intellectual property right of a third party.
- 10.1 The Buyer undertakes that it shall not solicit purchasers for the Goods outside countries which for the time being are Member States of the European Economic Area ("EEA State") or sell the Goods to any person who it knows is intending to use or resell the same outside the EEA States PROVIDED THAT nothing in this clause or elsewhere in these Conditions shall be construed so as to prevent the Buyer from selling or distributing the Goods in or to any EEA State to any person intending to use or resell the same in any EEA State.

Notices

- 11.0 Any notice required or authorised to be given hereunder shall be in writing and shall be served by registered mail sent to the address given above or any other address notified for the purpose and shall be deemed to be served seven days after proven despatch, provided that any other mode of service shall be valid if the said notice or other communication is actually received by the addressee.

Force Majeure

- 12.0 The Seller shall not be liable to the Buyer if unable to carry out any provision of the Contract for any reason beyond its control including (but without limitation) Act of God, legislation, war, civil commotion, fire, flood, drought, failure of power supply, lock out, strike, stoppage or other action by employees or third parties in contemplation or furtherance of any

dispute or owing to any inability to procure parts or materials required for the performance of the Contract.

Waiver

13.0 Any failure by the Seller to enforce any or all of these conditions shall not be construed as a waiver of the Seller's rights.

Construction and Jurisdiction

14.0 The proper law of the Contract shall be English law and the English courts shall have jurisdiction over any disputes arising thereunder. This edition of the Conditions of Sale dated October 2002 supercedes all previous editions.

APPENDIX A

SAFETY BULLETINS

Kidde Fire Protection GX20 Engineered FM-200 Fire Suppression Systems use pressurised equipment; therefore, personnel responsible for fire suppression systems must be aware of the dangers associated with the improper handling, installation or maintenance of this equipment.

Fire suppression system service personnel must be thoroughly trained in the proper handling, installation and service of GX20 equipment and follow the instructions used in this manual and in the Safety Bulletin and cylinder nameplate contained in this Appendix. Kidde Fire Protection has provided warnings and cautions at appropriate locations throughout the text of this manual. These warnings and cautions are to be adhered to at all times. Failure to do so may result in serious injury to personnel.

In addition, Material Safety Data Sheets for FM-200 and nitrogen are provided in Appendix B. Personnel must also be familiar with the information contained on these data sheets.

SAFETY BULLETIN 1, MARCH 2, 1987

SUBJECT: SAFE CYLINDER HANDLING PROCEDURES

DANGER!

PRESSURISED (CHARGED) CYLINDERS ARE EXTREMELY HAZARDOUS AND IF NOT HANDLED PROPERLY ARE CAPABLE OF VIOLENT DISCHARGE. THIS MAY RESULT IN SERIOUS BODILY INJURY, DEATH AND PROPERTY DAMAGE.

Before handling Kidde system products, all personnel must be thoroughly trained in the safe handling of the containers as well as in the proper procedures for installation, removal, filling and connection of other critical devices, such as flex hoses, control heads, discharge heads, and anti-recoil devices.

READ, UNDERSTAND and ALWAYS FOLLOW: the design, installation, operation and maintenance manual, the owners manual and other information that is provided with the individual systems.

The following safety procedures must be observed at all times:

Moving Container

Containers must be shipped compactly in the upright position and properly secured in place. Containers must not be rolled, dragged or slid, nor allowed to be slid from tail-gates of vehicles. A suitable hand truck, fork truck, roll platform or similar device must be used.

Rough Handling

Containers must not be dropped or permitted to strike violently against each other or other surfaces.

Storage

Containers must be stored standing upright where they are not likely to be knocked over, or the containers must be secured.

For additional information on safe handling of compressed gas cylinders, refer to "The Pressure Systems and Transportable Gas Containers SI 2169".

SAFETY BULLETIN 2, MAY 1, 1993

SUBJECT: SAFE CYLINDER HANDLING PROCEDURES FOR 25 BAR GX20 CYLINDERS

PRESSURISED (CHARGED) CYLINDERS ARE EXTREMELY HAZARDOUS AND IF NOT HANDLED PROPERLY ARE CAPABLE OF VIOLENT DISCHARGE. THIS WILL RESULT IN SERIOUS BODILY INJURY, DEATH AND PROPERTY DAMAGE.

BEFORE handling Kidde system products, all personnel must be thoroughly trained in the safe handling of the containers as well as in the proper procedures for installation, removal, filling, and connection of other critical devices, such as flexible hoses, control heads, and safety caps.

READ, UNDERSTAND and ALWAYS FOLLOW: the design, installation, operation and maintenance manual, the owners manual and other information that is provided with the individual systems.

THESE INSTRUCTIONS MUST BE FOLLOWED IN THE EXACT SEQUENCE AS WRITTEN TO PREVENT SERIOUS INJURY, DEATH OR PROPERTY DAMAGE.

Safety Cap

- (a) Each GX20 cylinder is factory equipped with a safety cap installed on the valve outlet, and securely chained to the valve to prevent loss. This device is a safety feature, and will provide controlled safe discharge when installed if the cylinder is actuated accidentally.
- (b) The safety cap must be installed in the valve outlet AT ALL TIMES except when the cylinders are connected into the system piping or being filled.
- (c) The safety cap is intentionally chained to the cylinder valve to prevent loss while in service and must not be removed from its chain.

Protection Cap

A protection cap is factory installed on the actuation port and securely chained to the valve to prevent loss. The cap is attached to the actuation port to prevent tampering or depression of the actuating pin. No attachments (control head, pressure control head) are to be connected to the actuation port during shipment, storage or handling.

Installation

THIS SEQUENCE FOR CYLINDER INSTALLATION MUST BE FOLLOWED AT ALL TIMES:

1. Install cylinder into bracketing.

WARNING

DISCHARGE HOSES OR VALVE OUTLET ADAPTOR MUST BE CONNECTED INTO SYSTEM PIPING BEFORE ATTACHING TO CYLINDER VALVE OUTLET TO PREVENT INJURY IN THE EVENT OF DISCHARGE.

2. Remove safety cap and connect all cylinder valves into system piping using flex hose or valve outlet adaptor.
3. Remove protection cap and attach control heads, pressure control heads, pilot loops, etc. as required.

WARNING

CONTROL HEADS MUST BE IN THE SET POSITION BEFORE ATTACHING TO THE CYLINDER VALVE ACTUATION PORT, IN ORDER TO PREVENT ACCIDENTAL DISCHARGE.

Removal From Service

1. Remove all control heads, pressure operated heads and pilot loops from cylinder valve; and attach protection cap to actuation port.
2. Disconnect cylinders from system piping at the valve outlet. Disconnect valve outlet adaptor, if used.
3. Immediately install safety cap on valve outlet.

DANGER!

DO NOT DISCONNECT THE CYLINDER FROM SYSTEM PIPING IF THE SAFETY CAP IS MISSING. OBTAIN A NEW SAFETY CAP FROM KIDDE FIRE PROTECTION LTD.

4. Remove cylinder from bracketing.

DANGER!

WARN TEXT = FAILURE TO FOLLOW THESE INSTRUCTIONS, AND IMPROPER USE OR HANDLING, MAY CAUSE SERIOUS BODILY INJURY, DEATH AND PROPERTY DAMAGE.

Safety Bulletin

No: 12 -2004	Date: 15 th June 2004
To: All Kidde Fire Protection Suppression Customers	
From: Lee James – Product Manager (Suppression)	

IMPORTANT SAFETY ANNOUNCEMENT

Additional Requirements for Return of Charged Cylinders to Kidde Fire Protection

Please share this bulletin with your management, installation staff and shipping personnel immediately.

It has been brought to our attention that pressurised cylinders are occasionally returned to Kidde Fire Protection in an unsafe condition. This is putting the freight carriers, Kidde Fire Protection employees and your personnel at a serious risk. The purpose of this Safety Bulletin is to remind our distributors of the risk and the safety precautions that need to be taken when working with high-pressure cylinders. Although many of us work with high-pressure cylinders every day, **DO NOT GET CARELESS!** Never assume the cylinder is empty; treat all cylinders as if they are fully charged. Pressurised (charged) cylinders are extremely hazardous and if not handled properly are capable of causing property damage, bodily injury and death.

The following safety precautions and instructions must be adhered to when returning pressurised cylinders.

1. Ensure all control heads, discharge heads, discharge hoses, piping or other types of actuation devices have been removed from the cylinder valve.
2. The valve protection cap, valve outlet and actuation port protection caps are installed on the cylinders prior to shipment. If they have been lost or damaged, please contact our Customer Services Department and we will be able to provide the necessary safety caps to help you with your return.
3. The enclosed Cylinder Returns Request Form must be completed correctly, including a valid returns number obtained from Customer Services and signed to confirm that the cylinders have been made safe. Additional copies can be obtained from our Customer Services Department.

Please note: Without a completed Cylinder Returns Form, our transport company will refuse to accept the shipment and a charge will be made.

4. In preparation for shipping, the charged cylinder must be secured in place, either on a pallet or equivalent, such that the cylinder can be safely stored and controlled during loading, transportation and off loading.

For additional information on safe handling of compressed gas cylinders, please refer to the appropriate Kidde Fire Protection Design, Installation, Operations and Maintenance manual, plus any local Health and Safety Legislation.

If you have any questions or concerns regarding this Safety Bulletin, please do not hesitate to contact us. As always, we thank you for your continued business and the support you have offered Kidde Fire Protection.

Lee James
Product Manager (Suppression)

3 PRODUCT RETURN REQUEST FORM	
KFP Return No. BW	Date
Customer Name	
Customer Address	
Customer Contact Name:	
Contact Telephone No: E Mail address: Fax No:	
Original Customer Order No:	
Original Kidde Ref No:	C0
Product Description:	
Product Part No:	
Reason for Return:	
Declaration: (Only applicable when returning pressurised or charged cylinders).	We confirm that the cylinder/s are/have been made safe in accordance with KFP Bulletin 12/2004 Signature: _____ Name : _____ Position : _____ Company: _____
Note:	A copy of this form must be faxed to the address below prior to return of goods.
Note:	A copy of this form must also accompany returned goods.
Note:	The transport company will not collect cylinders without a fully completed and signed copy of this form which must be attached to the shipment.
Ship to:	Kidde Fire Protection Services Ltd Station Road High Bentham Lancaster United Kingdom LA2 7NA Tel: 44 (0)15242 64000 Fax: 44 (0)15242 64180

BSD 027

APPENDIX B

MATERIAL SAFETY DATA SHEETS
